

Signal Transmission Solutions and Products



**An Overview of Cabling,
Connectivity and
Networking Capabilities**

Copper cable, fiber, wireless technology, connectors, switches and active components to bring voice, video and data to mission-critical applications.

Effective Signal Transmission Solutions

Belden® for the Best Solutions in the World

Belden designs, manufactures and markets high-speed electronic cables, connectivity products and related items for the specialty electronics and data networking markets. We focus on segments of the worldwide cable and connectivity market that require highly differentiated, high-performance products. We add value through design, engineering, excellence in manufacturing, product quality and customer service.

Total Connectivity Solutions Supplier

Belden is a total connectivity solutions provider. We are able to offer total connectivity solutions with a portfolio that includes the full range of Lumberg Automation™ connectors, Hirschmann™ connectors and switches and Belden® cables, supported by a strong and experienced team of experts.

Reducing Total Cost of Ownership

A key consideration is Total Cost of Ownership (TCO). We are able to offer our existing customers significant benefits as we set out to reduce their Total Cost of Ownership. Because we are not locked into any proprietary protocol we are able to offer solutions around any protocols. And if a specific proprietary protocol does not exist, we are able to create a customer specific solution.

Belden has manufacturing capabilities throughout North America, Europe and Asia and a market presence in every region of the world.

Sending all the Right Signals

From industrial automation to data centers, from broadcast studios to aerospace, from cutting-edge wireless communications to consumer electronics, Belden people are committed to delivering the best signal transmission solutions. Our team works around the world in copper cable, fiber, wireless technology, connectors, switches and active components to bring voice, video and data to your mission-critical application.





Closer to Your Needs

A Strong Tradition of Excellence

Belden® brings together the business know-how and technologically advanced products of four leading brands: Belden, Hirschmann™ and Lumberg Automation™. With a combined history of over 100 years, Belden has established a strong reputation for quality, setting, maintaining and exceeding new standards of performance and reliability. In addition, Belden is committed to fulfilling the highest standards in terms of ethical conduct and integrity at all times and in all places.

Meeting Customer Needs

Belden signal transmission solutions are used by customers around the globe for mission-critical applications. They trust our ability to understand their needs and meet their expectations. Time after time we are able to deliver tailor-made integrated solutions. We have a very successful track-record reducing complexity, improving overall performance and maximizing return on investment.

Setting Global Standards

Belden focuses on the specific needs of its local customers. However, as a globally operating company, we develop our solutions to the highest standards, based on best practices and experience around the world. Customers benefit from our central R&D facilities and our around-the-clock responsiveness to meet their needs. As a global company, we are able to propose better solutions to more customers from regional and global accounts.

Leadership in Technology

Belden is committed to providing the best solutions. This commitment is not just for today, but also for the future. To ensure that customers can continue to benefit from the added value of Belden products and applications, we invest in innovation. This is clearly demonstrated by our numerous patents. The technical design, the choice of materials and the production processes all comply with the qualitative requirements set by customers from a wide range of industries.

Strong Contribution to Industry

Belden develops individual solutions for its customers. Through ongoing research and development, Belden brings to market the very best in products and solutions. As a market leader, we also play an active role in key industry associations around the world – thus helping to develop standardization for global applications and products. We are active in IEC, IEEE, ODVA, PNO, EPSG, as well as numerous manufacturer-independent organizations.



Why Professionals Choose Belden

Belden® stands for high quality, high performance and reliability, all the time and in any market. Countless successful applications have earned us a worldwide reputation as an expert solutions provider with high performance, quality products and an innovative approach.

Our very wide range of signal transmission products ensures that you benefit from the most cost effective solutions as well as the necessary data and back-up support. So you can be sure you are working with the very best products in signal transmission technology and, where needed, complete systems

Customers tell us the following 10 reasons why they choose to work with Belden.

- 1) World-class products with proven superior performance.
- 2) Wide range of standard and tailored signal transmission solutions from one single source.
- 3) Fast delivery of solutions and ease of installation.
- 4) Belden, Hirschmann™ and Lumberg Automation™: brands with a long history and an excellent reputation.
- 5) Reliability for minimum maintenance and maximum uptime.
- 6) Hassle-free and secure signal transmissions under the toughest conditions.
- 7) Local technical support backed by extensive global resources.
- 8) Permanent analysis of market needs for continuous development of effective solutions.
- 9) Design support and innovation.
- 10) Reducing total cost of ownership.

Whatever your industry and specific requirements – contact Belden for solutions that will meet and exceed your expectations.





Belden: An Overview of Markets and Solutions

This catalog was created to provide an overview of the key markets we currently serve – and the products we offer in those specific markets. Although we do not set out to give a complete overview, we believe that the following pages will show the breadth of our portfolio and demonstrate the depth of our experience.

For more information and a complete overview, please visit our website www.beldensolutions.com

Table of Content	Page
Vertical Markets	6–25
Alternative Power Generation – Wind Farms	6–7
Alternative Power Generation – Photovoltaic Parks	8–9
Public Transport	10–11
Traffic Control	12–13
Machine Building – Robotics	14–15
Machine Building – Material Handling	16–17
Oil & Gas	18–19
Professional Broadcast	20–21
Professional Audio & Video	22–23
Data Center	24–25
Service Overview	26
The Belden® Competence Center	27
Hirschmann™ – The Technology and Market Leader in Industrial Networking	28–53
Lumberg Automation™ and Hirschmann™ – For Sophisticated and Superior Industrial Connectivity Solutions	54–63
Belden – Wire and Cable Solutions for High Quality, Top Performance and Total Reliability	64–93

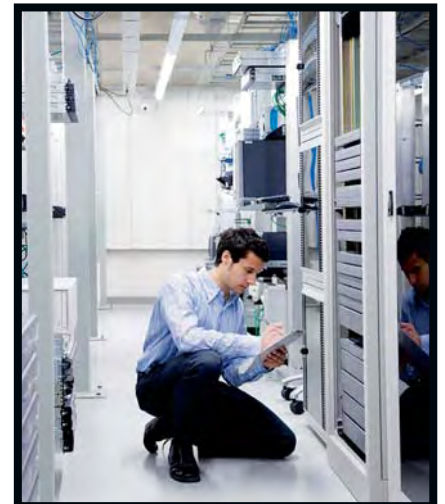

Alternative Power Generation – Wind Farms

Reliable solutions for onshore and offshore applications, reducing downtime and meeting reliability, safety and security needs for effective wind farm management.

Stable and Secure

For a wind park, stable operation is essential. With security and safety of the utmost importance, Belden® meets the highest customer requirements and standards, even under the most challenging conditions, including temperature differences, humidity and vibrations. Being one of the world's leading suppliers of connectivity solutions for wind farms, Belden solutions are found in around 80% of European made wind turbines. Working with all leading suppliers in this sector, Belden continues to develop innovative and real life solutions for both onshore and offshore wind power applications.



Maintenance

Maintenance within a wind turbine can be carried out without any communication risk, as the backbone can be isolated from the turbine during the service. This means that even when the maintenance takes place, the seamless flow of information around the wind park is not interrupted.

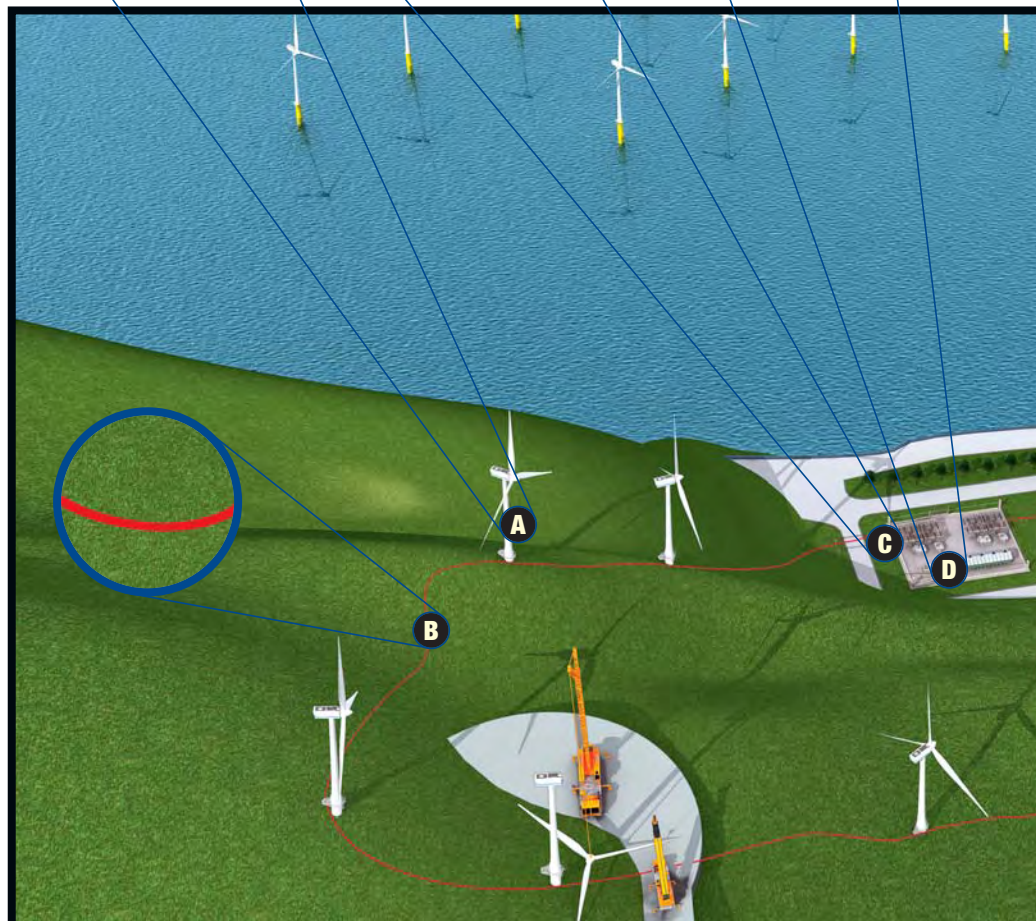



A Wind Turbine Nacelle and Tower

BAT Family

- Wireless access points and clients
- Bridge functionality
- Redundant WLAN links for reliable data transfer
- IP67 protection class



Connectivity Solutions

- Actuator/sensor connecting and interconnecting cables
- Field attachable connectors
- M8, M12, M23, 7/8"
- Valve connectors A, B and C design
- IP65 – IP69K protection class



SPIDER Family

- Entry-level switches in many varieties
- Fast Ethernet or full gigabit
- Fiber to copper conversion
- Unmanaged
- 2 to 8 (+2) ports plus optional optical fiber ports



OpenRail Family

- Redundant power supply
- Available in customized versions
- Available with conformal coating



FiberExpress® System

- FiberExpress® Manager easy patch cords routing and management in a minimum space
- FiberExpress® Bar: a compact, modular and resilient linking panel
- Optimax connectors for fast, secure and reliable field installable fiber termination



Fieldbus Repeater

- For the most common Fieldbus protocols
- Predictive maintenance
- Protocol specific Fieldbus repeaters available



Fieldbus Systems and Distributors

- Fieldbus modules for AS-Interface, DeviceNet, CANopen® and Profibus
- Actuator/sensor distribution box
- IP67/IP69K protection class, vibration and shock resistant



Ethernet Cables

- FiberExpress® fiber and IBDN copper LAN cable

Industrial Ethernet Cables

- IP67, CAT5e
- Black UV resistant cable jacket
- PVC/FRNC or PUR cable jacket available



MICE Family

- Modular switch family
- Extensive range of hot-swappable media modules
- Maximum flexibility by comprehensive selection of media types
- Supports a comprehensive selection of connectors
- MICE PoE media modules available



B Connection Between Wind Turbines

Fiber Cables

- Direct burial, duct or outside devices
- For inside and outside use FRNC/LSNH
- Weather resistant
- Protection from mechanical and rodent damage with or without metallic armour
- Multimode or singlemode



OCTOPUS Family

- First manageable ruggedized IP67 PoE switch
- Extended management by SNMP
- Redundancy via HIPER-Ring/MRP and Rapid Spanning Tree
- Access control via IEEE 802.1X



C Substation

MACH1000

- Rack-mount ruggedized switch
- Maximum uptime in extreme environmental conditions
- Extended temperature range: -40°C up to +85°C



RSR

- Compact ruggedized DIN Rail Switches
- Extremely high EMI resistance
- Withstands tremendous shocks and vibration



D Control Room

MACH100

- Modular fanless Industrial Ethernet rack mount switch
- Hot-swappable modules
- Optional redundant power supply



MACH4000

- Gigabit backbone routing switches
- Up to 48 Gigabit Ethernet ports and three 10 Gigabit Ethernet ports
- Highly redundant



EAGLE Family

- High-speed VPN, firewall and routing solution
- Transparent and routing mode
- Various media connection options
- 9.6 V up to 60 VDC redundant inputs



Alternative Power Generation – Photovoltaic Parks

Cost Effective and Consistent

In photovoltaic parks, conditions can be extremely challenging: temperatures, humidity and UV radiation can vary; panels may be susceptible to vibrations; and electromagnetic interference is an issue. Based on years of experience in the energy market, Belden® offers solutions designed to meet every specific requirement. In a business where cost effective installation and stable operation are essential, minimum interruption and maximum availability is a result of Belden's high-quality products and redundancy techniques.

Integrated solutions for the fast, easy and safe installation and operation of photovoltaic parks in challenging environments.

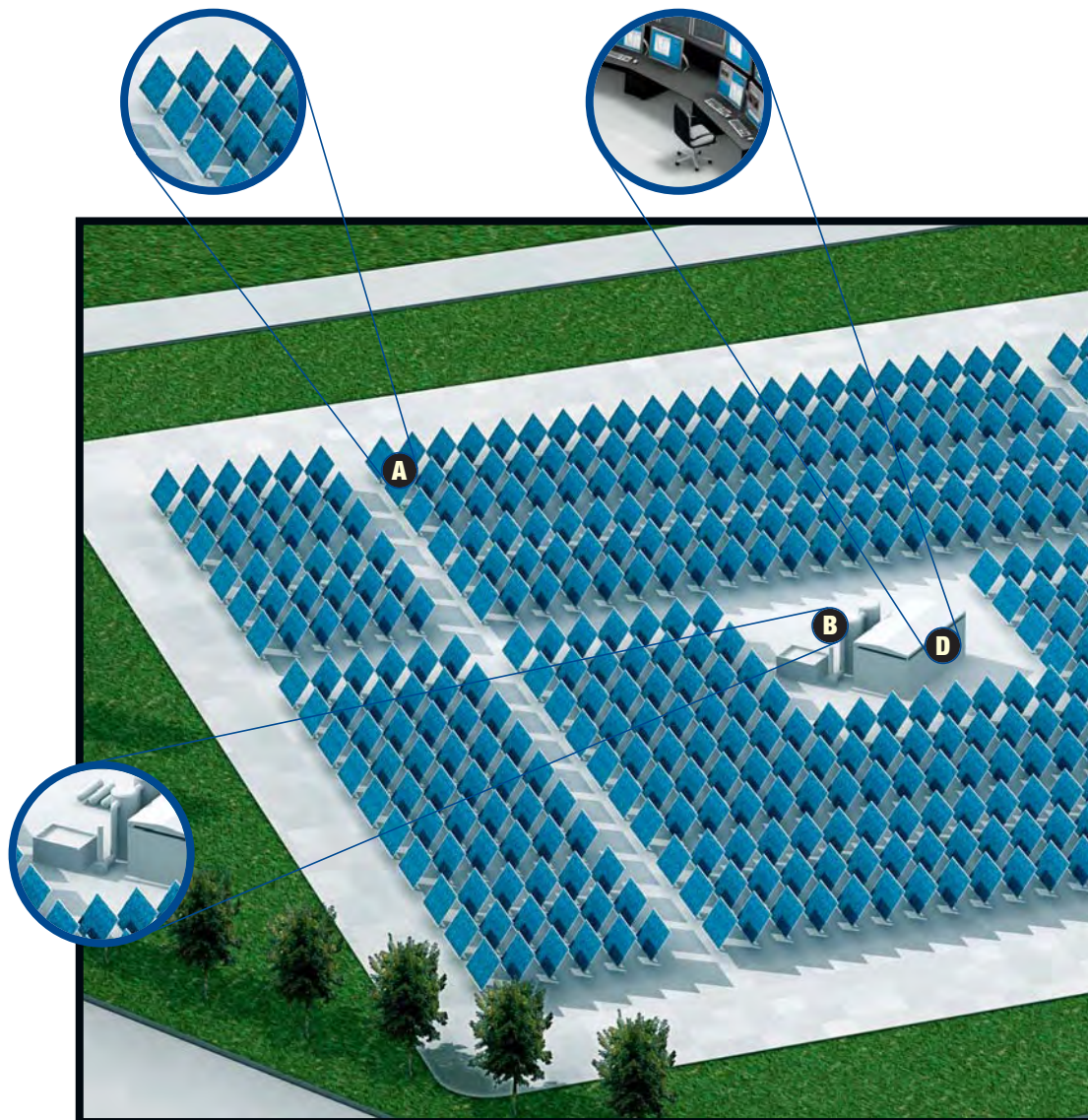



A Connection of Solar Panels

SunCon1 – Cable Plug and Socket

- Cable plug and socket
- Robust, elastic, insulating body with locking
- 1000 VDC
- IP68



SunCon1– Appliance Plug and Socket

- 1000 VDC
- IP68



Y-Splitter

- 1000 VDC
- IP68



B Communication System

SPIDER Family

- Entry-level switches in many varieties
- Fast Ethernet or full gigabit
- Fiber to copper conversion
- Unmanaged
- 2 to 8 (+2) ports plus optional optical fiber ports



Fieldbus Repeater

- Fieldbus modules for AS-Interface, DeviceNet, CANopen® and Profibus
- Actuator / sensor distribution box
- IP67 / IP69K protection class, vibration and shock resistant



OpenRail Family

- Redundant power supply
- Available in customized versions
- Available with conformal coating



FiberExpress® System

- FiberExpress® Manager easy patch cords routing and management in a minimum space
- FiberExpress® Bar: a compact, modular and resilient linking panel
- Optimax connectors for fast, secure and reliable field installable fiber termination



BAT Family

- Wireless access points and clients
- Bridge functionality
- Redundant WLAN links for reliable data transfer
- IP67 protection class



Ethernet Cables

- FiberExpress® fiber and IBDN copper LAN cable

Industrial Ethernet Cables

- IP67, CAT5e
- Black UV resistant cable jacket
- PVC/FRNC or PUR cable jacket available



Basic Switches

- Best cost-performance ratio
- Feature range ideal for redundant networks
- Variants from fixed 8TX ports up to the flexible version with 3 FE SFP uplink ports
- Comprehensive redundancy software features



C Substation

MACH1000

- Rack-mount ruggedized switch
- Maximum uptime in extreme environmental conditions
- Extended temperature range: -40°C up to +85°C



RSR

- Compact ruggedized DIN Rail Switches
- Extremely high EMI resistance
- Withstands tremendous shocks and vibration



D Control Room

MACH100

- Modular fanless Industrial Ethernet rack mount switch
- Hot-swappable modules
- Optional redundant power supply



MACH4000

- Gigabit backbone routing switches
- Up to 48 Gigabit Ethernet ports and three 10 Gigabit Ethernet ports
- Highly redundant



EAGLE Family

- High-speed VPN, firewall and routing solution
- Transparent and routing mode
- Various media connection options
- 9.6 V up to 60 VDC redundant inputs

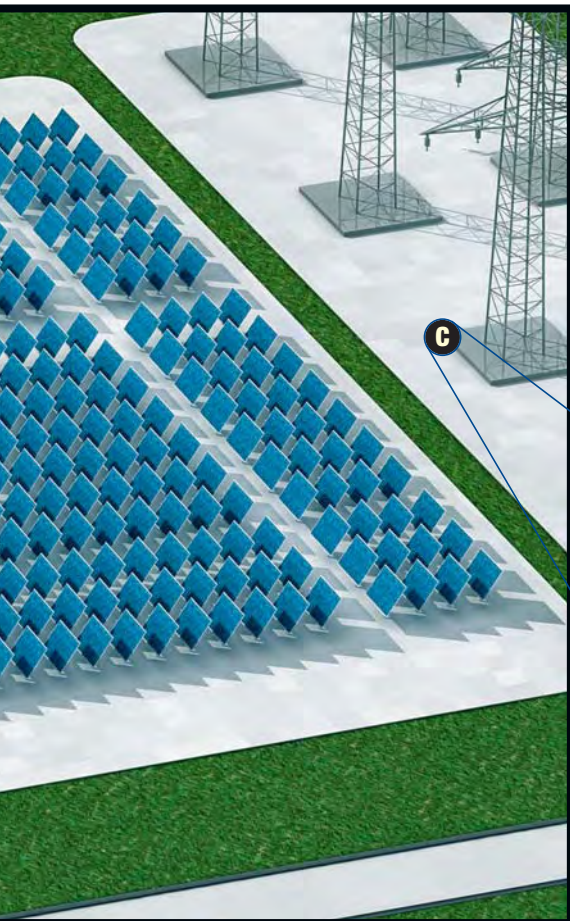

Public Transport

Reliable and Safe

In a sector where security and availability are key, Belden® works closely with the leading players in public transport and provides them with seamless solutions that offer real time information for operators and passengers, on-board as well as in terminals and control rooms. Belden offers innovative products and has supported the introduction of wireless on-board entertainment systems and track-side infrastructure. Key European companies, ranging from operators of high-speed trains to local trams, rely on Belden solutions to guarantee passenger safety and comfort around the clock.

Bringing passenger safety and comfort to transport systems, as well as ensuring security of rolling stock, terminals and infrastructure.

A In Between Wagon Communication

BAT Family

- Wireless access points and clients
- Bridge functionality
- Redundant WLAN links for reliable data transfer
- IP67 protection class



Cables

- UIC cables for internal and external vehicle wiring
- WTB and MVB data bus cables

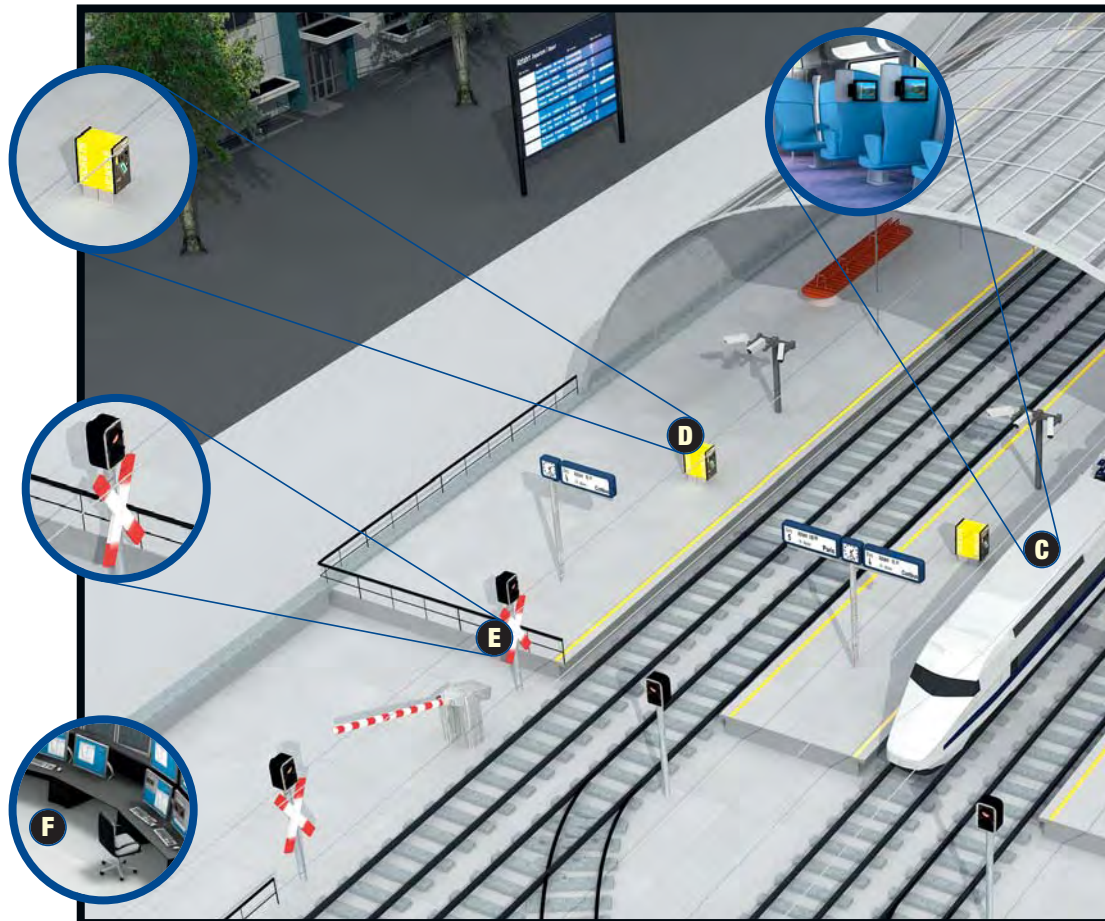



B Video Surveillance

OCTOPUS Family

- Ruggedized switch family for extreme conditions
- Open system with standardized M12 technology
- IP67 protection class and EN 50155 approvals
- Extended management by SNMP
- Redundancy via HIPER-Ring/MRP and Rapid Spanning Tree
- Available with PoE



BAT Family

- Wireless access points and clients
- Bridge functionality
- Redundant WLAN links for reliable data transfer
- IP67 protection class



Cables

- Data communication cables with EN 50155 approvals



Receptacle Connectors

- Standard connectors or individual solutions "straight out of a construction kit"
- Multiple options for external chassis threads



EAGLE Family

- High-speed VPN, firewall and routing solution
- Transparent and routing mode
- Various media connection options
- 9.6 V up to 60 VDC redundant inputs



E Signaling Technology

Ethernet Connectors

- IP67 Ethernet Connector
- Industrial M12 technology
- Optical and electrical contacts



OCTOPUS Family

- Ruggedized switch family for extreme conditions
- Open system with standardized M12 technology
- Extended management by SNMP
- IP67 protection class
- Redundancy via HIPER-Ring/MRP and Rapid Spanning Tree



Connectivity Solutions

- Actuator/sensor connecting and interconnecting cables
- Field attachable connectors
- M8, M12, M23, 7/8"
- Valve connectors A, B and C design
- IP65 – IP69K protection class



C Passenger Information System

OCTOPUS Family

- Ruggedized switch family for extreme conditions
- Open system with standardized M12 technology
- Extended management by SNMP
- IP67 protection class
- Redundancy via HIPER-Ring/MRP and Rapid Spanning Tree



MACH Family

- Modular fanless Industrial Ethernet rack mount switch
- Hot-swappable modules
- Optional redundant power supply
- Up to 48 Gigabit Ethernet ports and three 10 Gigabit Ethernet ports
- Highly redundant



Cables

- Data communication cables with EN 50155 approvals



F Control Room

MACH Family

- Modular fanless Industrial Ethernet rack mount switch
- Hot-swappable modules
- Optional redundant power supply
- Up to 48 Gigabit Ethernet ports and three 10 Gigabit Ethernet ports
- Highly redundant



Industrial HiVision

- Topology Discovery
- SNMP Trap support
- Auto Discovery
- Configuration and extended diagnosis are provided via interfaces, including HiVision 6.4, Web browser and TELNET



IBDN Cables

- Full range of copper cables
- Full range of fiber cables



D Train-to-ground Communication

BAT Family

- Wireless access points and clients
- Bridge functionality
- Redundant WLAN links for reliable data transfer
- IP67 protection class



EAGLE Family

- High-speed VPN, firewall and routing solution
- Transparent and routing mode
- Various media connection options
- 9.6 V up to 60 VDC redundant inputs



Traffic Control

Robust and Reliable

Seamless solutions for the efficient flow of traffic through realtime information and control in challenging environments and changing weather conditions.

Traffic control systems need to be completely reliable and robust, even under the most challenging conditions. Safety must not be compromised at any time and systems should offer high availability throughout their long service life. Belden® works with operators, manufacturers and systems integrators, who all rely on Belden to provide them with seamless solutions that meet their most advanced requirements, backed up by engineering, professional service and technical support.

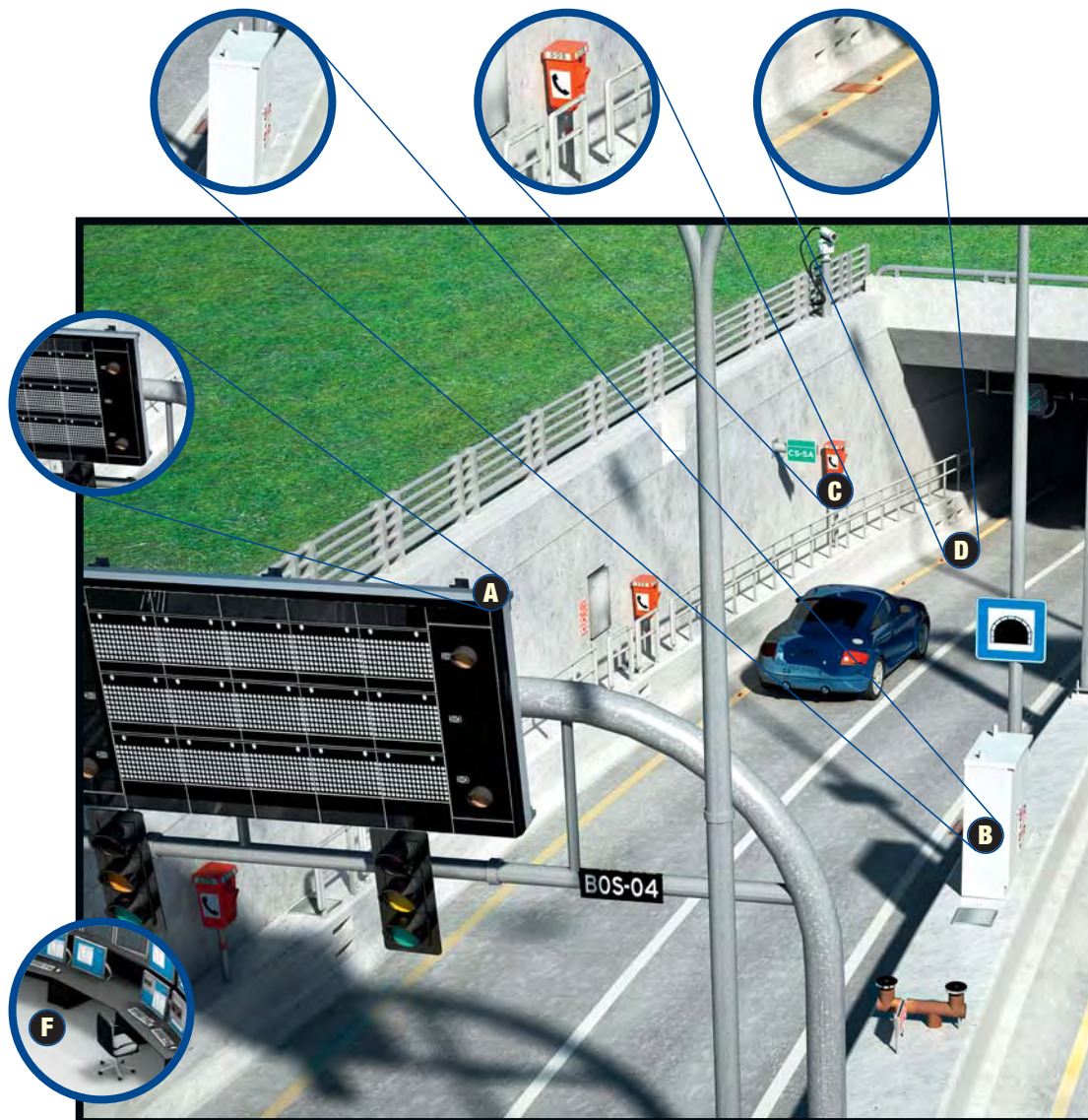



A Traffic Control Systems

BAT Family

- Wireless access points and clients
- Bridge functionality
- Redundant WLAN links for reliable data transfer
- IP67 protection class



B Traffic Redirection

Fieldbus Repeater

- Fieldbus modules for AS-Interface, DeviceNet, CANopen® and Profibus
- Actuator/sensor distribution box
- IP67/IP69K protection class, vibration and shock resistant



Fieldbus Systems and Distributors

- Fieldbus modules for AS-Interface, DeviceNet, CANopen® and Profibus
- Actuator/sensor distribution box
- IP67/IP69K protection class, vibration and shock resistant



Fieldbus Cables

- RS-485 cables



MACH100 Family

- Modular fanless Industrial Ethernet rack mount switch
- Optional redundant power supply
- Hot-swappable modules
- Highly redundant



OpenRail Family

- Redundant power supply
- Available in customized versions
- Available with conformal coating



MICE Family

- Modular switch system
- Gigabit router option
- Extensive range of hot-swappable media modules



E Video Surveillance

OpenRail Family

- Redundant power supply
- Available in customized versions
- Available with conformal coating
- Available with PoE



BAT Family

- Wireless access points and clients
- Bridge functionality
- Redundant WLAN links for reliable data transfer
- IP67 protection class



OCTOPUS Family

- Ruggedized switch family for extreme conditions
- Open system with standardized M12 technology
- Extended management by SNMP
- IP67 protection class
- Redundancy via HIPER-Ring/MRP and Rapid Spanning Tree
- Available with PoE



C Emergency Telephones

BAT Family

- Wireless access points and clients
- Bridge functionality
- Redundant WLAN links for reliable data transfer
- IP67 protection class



OpenRail Family

- Redundant power supply
- Available in customized versions
- Available with conformal coating
- Available with PoE



F Control Room

MACH100 Family

- Modular fanless Industrial Ethernet rack mount switch
- Hot-swappable modules, highly redundant
- Optional redundant power supply



Industrial HiVision

- Topology Discovery
- SNMP Trap support
- Auto Discovery
- Configuration and extended diagnosis are provided via interfaces, incl. HiVision 6.4, Web browser and TELNET



IBDN Cables

- Full range of copper cables
- Full range of fiber cables



EAGLE Family

- High-speed VPN, firewall and routing solution
- Transparent and routing mode
- Various media connection options
- 9.6 V up to 60 VDC redundant inputs

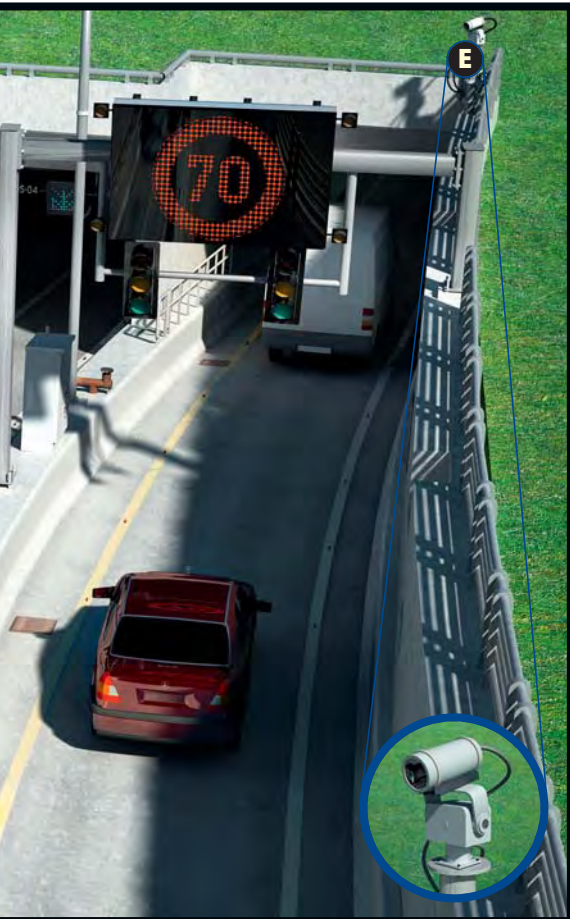

Machine Building – Robotics

Leading-edge and Trusted

Belden® has been working closely with system integrators and end customers in the machine building market for many years. Based on this experience, Belden is able to offer customized solutions using a wide range of products based on leading edge technologies, designed to meet the latest market-standards. For instance, many if not all leading automotive producers trust Belden solutions and have authorized their use in new machines and for Maintenance, Repair and Overhaul (MRO).

Delivering perfect performance in the toughest of conditions, whilst reducing downtime thanks to resistance to torsion, vibration and oil.

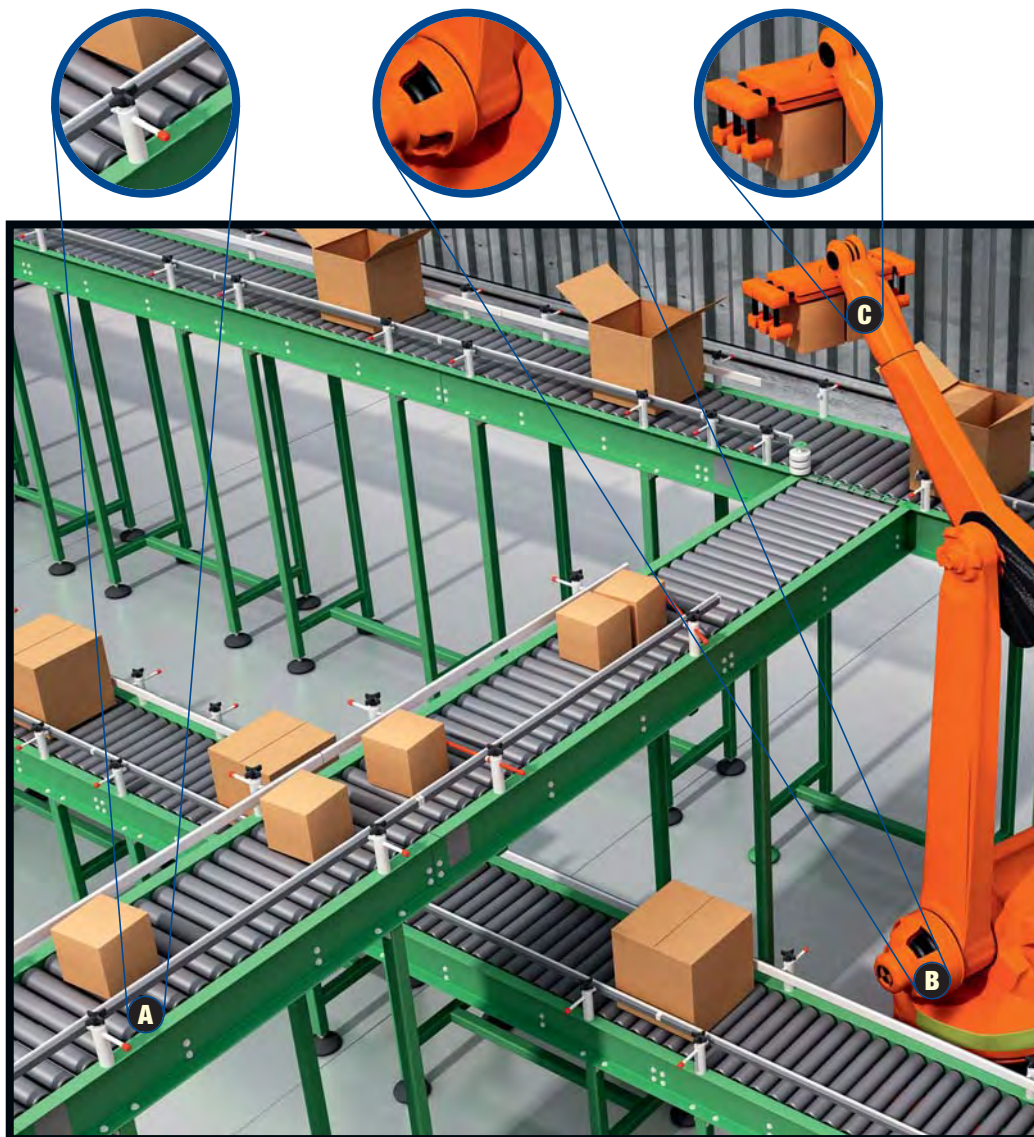



A I/O & Motion Control

LioN-Link

- Two line per bus head (for Profinet, Profibus, DeviceNet, CANopen®)
- Fieldbus independent I/O Modules – up to 100 m extension per line – up to 15 devices per line



LioN-Link Motion

- Control of 24 V brushless drive technology
- Reduced amount of cabling
- Reduced installation time
- High level diagnostics
- Parameter setup



Connectivity Solutions – Actuator/Sensor Double Ended and Single Ended Cordsets (M8/M12)

- Reduced installation time
- Easy to maintain
- IP67 protection class
- Torsion-suitable
- Suitable for use in drag chains
- Vibration- and shock resistant
- Good chemical and oil resistance



B Robot Base

E2C67

- IP67
- Modular Fieldbus station
- Flexible I/O combination
- Bus head for Profibus, Interbus, DeviceNet, Ethernet (TCP/IP)
- Ruggedized backplane concept



Octopus Family

- Manageable ruggedized IP67 PoE switch
- Extended management by SNMP
- Access control via IEEE 802.1X



C Robot Grip

Actuator/Sensor Distribution Box

- Space saving design
- Cost saving wiring
- Easy to maintain
- Shock and vibration proof
- IP67 protection class



LioN-M/LioN-S

- Universal I/O functionality
- Unlimited I/O combination
- Exact diagnostic
- Space saving in the cabinet
- Fieldbus protocols: Profibus, DeviceNet



MicroFX

- IP67 Ethernet connector
- Optical and electrical contacts
- Industrial M12 connector

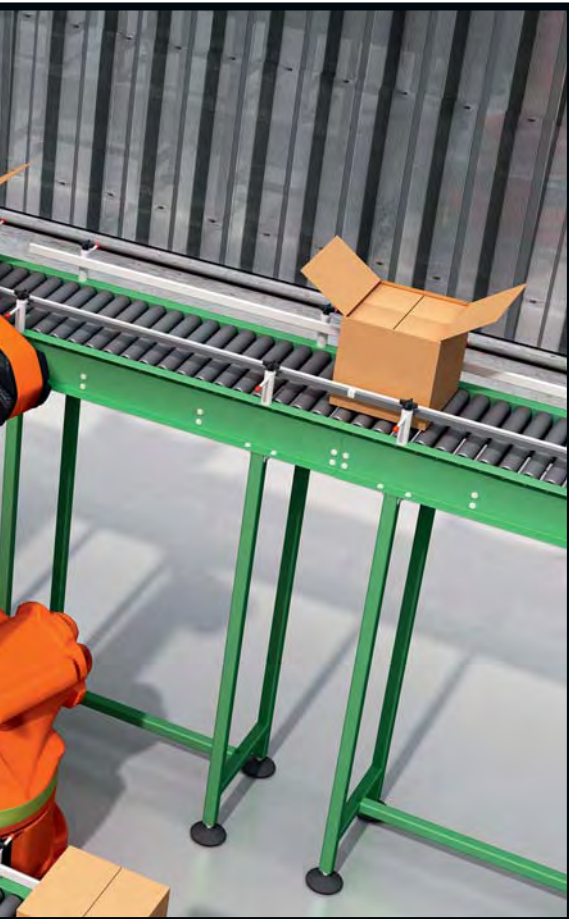

Machine Building – Material Handling

Experienced and Easy-to-Connect

In environments where availability is a must, such as transport belts, assembly-cells and packaging lines, Belden® has completed many projects with many of the world's leading manufacturers. With a wide product range covering technologies as different as Ethernet communication and analogous I/O signals, Belden has the right products for all environments including those where space is limited with the benefit of reduced installation time and maintenance.

Bringing improved reliability and increased productivity as well as a reduction in downtime and a smaller footprint, whilst meeting established standards.

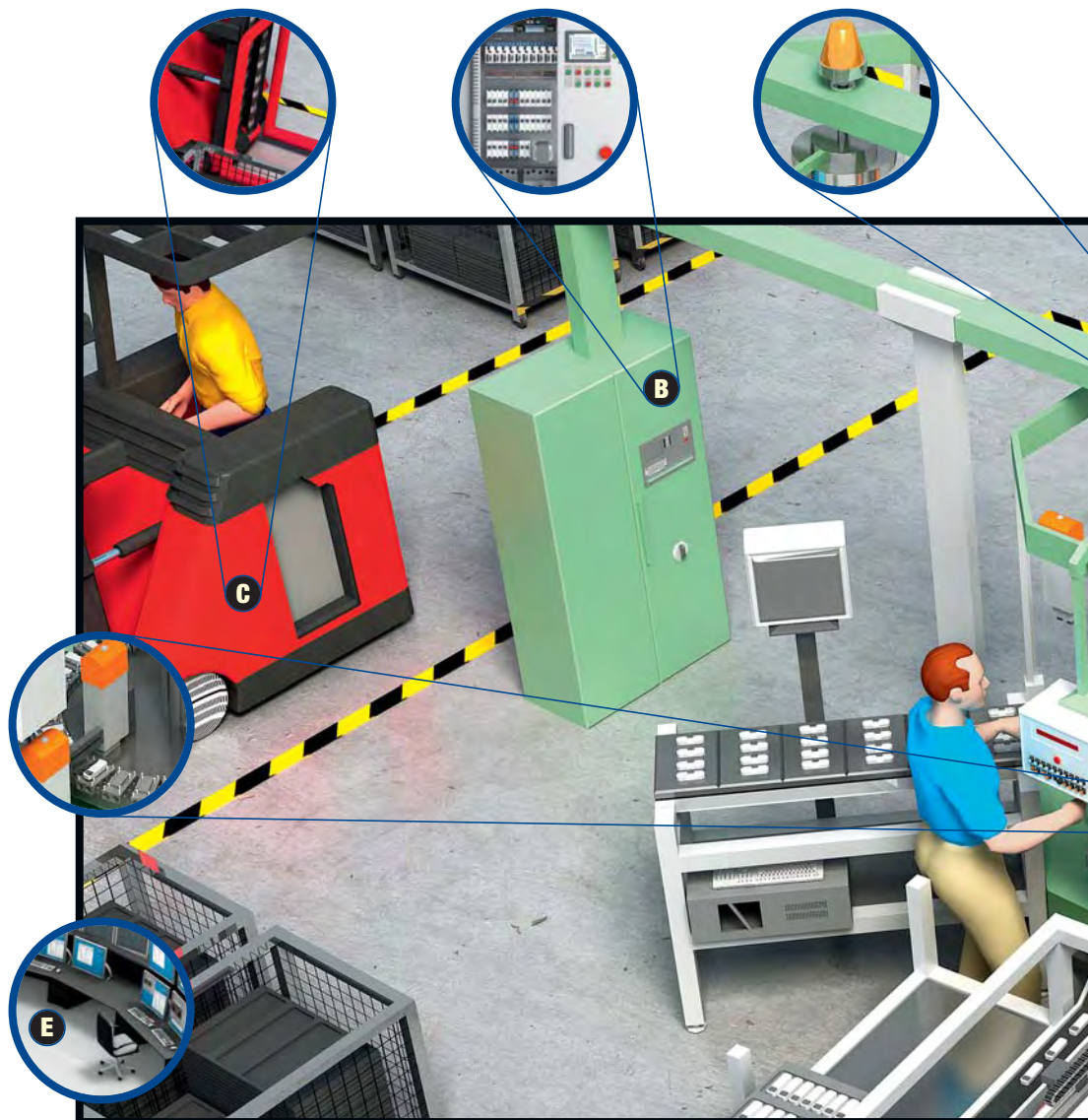



A Workstation

Connectivity Solutions – Actuator/Sensor Cordsets (M8/M12), Valve and Field Attachable Connectors, Industrial Ethernet Connectivity

- Reduced installation time
- Easy to maintain
- IP67 protection class
- Good chemical and oil resistance



Actuator/Sensor Distribution Box

- Space saving design
- Cost saving wiring
- Easy to maintain
- Shock and vibration proof
- IP67 protection class

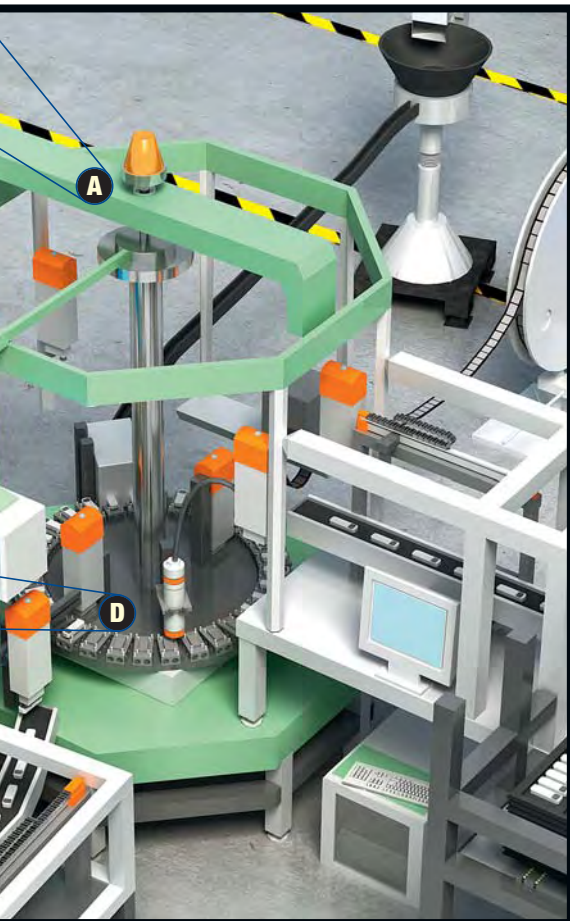

Fieldbus Modules – LiON-M/LiON-S, LiON-Link, E2C67

- Universal I/O functionality
- Unlimited I/O combination
- Exact diagnostic
- Space saving in the cabinet



BAT Client

- Single LAN – IEEE802.11b/g
- Up to 108 Mbps bandwidth
- Redundant 24 VDC power inputs



BAT Family

- Wireless access points
- Bridge functionality, IP67
- Redundant WLAN links for reliable data transfer



B Cabinet

Fieldbus Repeater

- Support most common Fieldbus protocols



MICE Family

- Modular switch system
- Gigabit router option
- Extensive range of hot-swappable media modules



RS PoE Switches

- Power over Ethernet
- Redundant power inputs
- Available with conformal coating
- Extended temp. range: -40°C to +60°C



Open Rail Family

- Industrial Ethernet switches
- Redundant power inputs
- Customized solutions available
- Available with conformal coating
- Extended temp. range: -40°C to +70°C



BAT Family

- Wireless access points
- Bridge functionality, IP67
- Redundant WLAN links for reliable data transfer



C Forklift

BAT Family

- Wireless access points
- Bridge functionality, IP67
- Redundant WLAN links for reliable data transfer



BAT Client

- Single LAN – IEEE802.11b/g
- Up to 108 Mbps bandwidth
- Redundant 24 VDC power inputs



D Signal Transmission

Fieldbus Systems – LiON-M/LiON-S, LiON-Link, LiON-Link Motion, E2C67

- Motion control (24 V roller conveyor motors)
- Universal I/O functionality
- Unlimited I/O combination
- Exact diagnostic
- Space saving in the cabinet
- IP67 protection class



Field Attachable Connectors

- M8, M12, 7/8", M23
- IP65/67
- Straight and angled versions, 4, 5, 8, 12, 19-poles



Connectivity Solutions – Actuator/Sensor Double Ended and Single Ended Cordsets (M8/M12)

- Reduced installation time
- Easy to maintain
- IP67 protection class
- Torsion- suitable
- Suitable for use in drag chains
- Vibration- and shock resistant
- Good chemical and oil resistance



Connectivity Solutions – Actuator/Sensor Cordsets (M8/M12), Valve and Field Attachable Connectors

- Reduced installation time
- Easy to maintain
- IP67 protection class



E Control Room

EAGLE20

- High speed VPN, firewall and routing solution
- Various media connection options



Mach100

- Modular fanless Industrial Ethernet switch
- Hot-swappable modules
- Rack mounted



Oil & Gas

Recognized and Reliable

Tried and trusted solutions and a proven track record of reliability and certification in some of the biggest projects in the industry.

With a comprehensive range of ultra-reliable products designed with the exceptional challenges of the oil & gas industry in mind, Belden® provides customers with unique, proven solutions that meet even their most demanding requirements. Belden's portfolio enables the seamless sharing of information throughout a facility to maximize security and productivity. As the supplier of choice for pipeline and refinery installations, on-shore and off-shore, Belden also works with leading players in the industry to introduce new technologies, in areas such as wireless, to manage processes at a new oil refinery.

Control

Due to the continuously growing demands for safety and productivity in process industries, control systems are becoming ever more advanced and widely used. The infrastructure needs to be able to meet these changing requirements. Belden's comprehensive portfolio, ranging from Ethernet and Fieldbus to connectors and cables, across copper, fiber and wireless offers an unrivalled choice of field-proven technologies to facilitate optimal performance over the long-term.

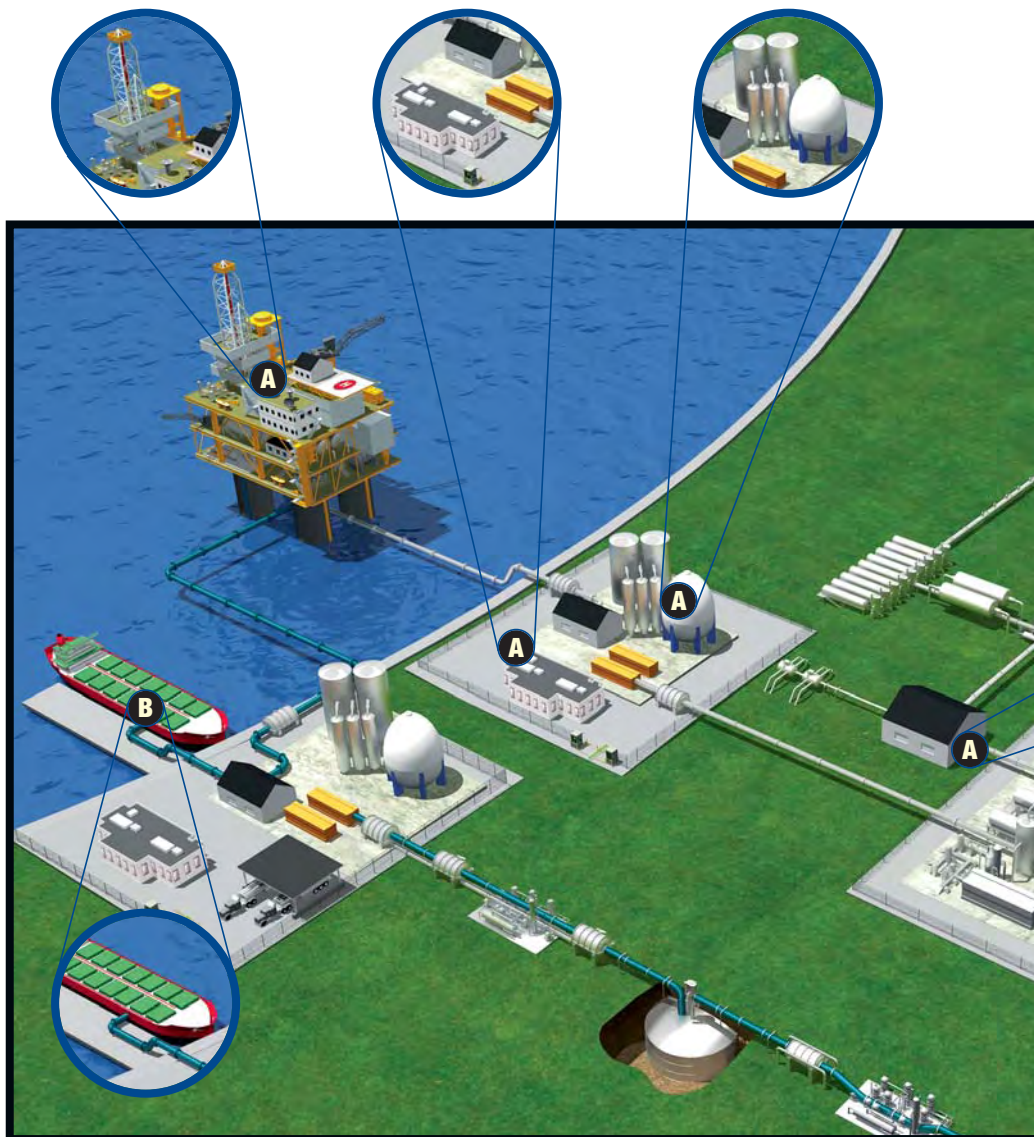



A General Applications

Range of Fieldbus Cables

- Ultra-reliable
- Built to meet exact jacketing specifications
- Consistent performance over time and distance



Instrumentation & Control Cables (HART compatible)

- Low-cost, high performance cables
- Jacketed/armoured to meet specified requirements
- Range of industry certifications



Wireless Products

- Simple, powerful
- EMI resistant connectivity for wireless devices



Range of Industrial Connector Products (Valve Connectors, MB, M12)

- Connectivity designed to withstand extremes of temperature, pressure, impact and environment



Industrial Ethernet Backbone, Control and Field Level Switches & Security Products

- Extremely powerful hardware and management infrastructure for all Industrial Ethernet applications
- With rack, rail and field mounting options



Fieldbus Interface/Gateway Devices

- Simple, reliable connection between your Fieldbus & Ethernet infrastructures



Security & Access Control Cabling

- Low-cost, high performance cables
- Designed specifically for security installations



Variable Speed Drive Cabling

- Cables designed to manage the specific issues surrounding harmonics and voltage spikes



B Specialist Applications

Shipboard Fiber & Copper Cabling

- Huge range of cables manufactured to relevant off-shore standards

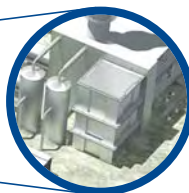
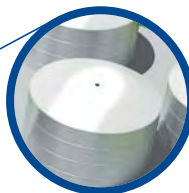
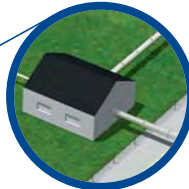

Professional Broadcast

Perfect and Professional

World-class solutions for HD and 3G applications from the global leader in reliability and high quality required for “live” events.

Hundreds of millions of viewers around the world depend on Belden® for reliability and quality when they are watching live coverage of the world’s largest sports events or following the unfolding of the latest news story on the radio in high definition (HD). Designed for the perfect capturing, processing, routing and delivery of content, Belden cables are the first choice for TV/Radio stations, film and recording studios, performance and sports venues. They are also used extensively in audio, video, lighting and camera applications. Providing top performance and high reliability, Belden is able to meet the specific requirements of even the most demanding technological constraints.

A Camera

Triax Cable

- HD designed (1080p); around 1.2 km distance
- Silver-plated copper conductor & braid
- Guaranteed return loss performance
- Crush resistant dielectric
- Very low attenuation
- Available for in- and outdoor usage
- Excellent picture quality



Hybrid Fiber Cable

- HD designed (1080p); around 4 km distance
- SMPTE311 compliant
- Three versions have flexible black jackets (with very low memory effect) in either halogen-free, PUR or PVC
- Belden’s “easy-access” put-up enables easy connection on the drum



High-Definition

To support the growing bandwidth needs of HD applications, Belden’s HD designed coaxial cables are the perfect choice for the next generation 1.5 Gps (HD) and 3 Gps (1080p) infrastructures. Belden offers Installable Performance™. This means that after installation, the cables will deliver excellent picture quality and extended transmission distances, with guaranteed levels of return loss and headroom.

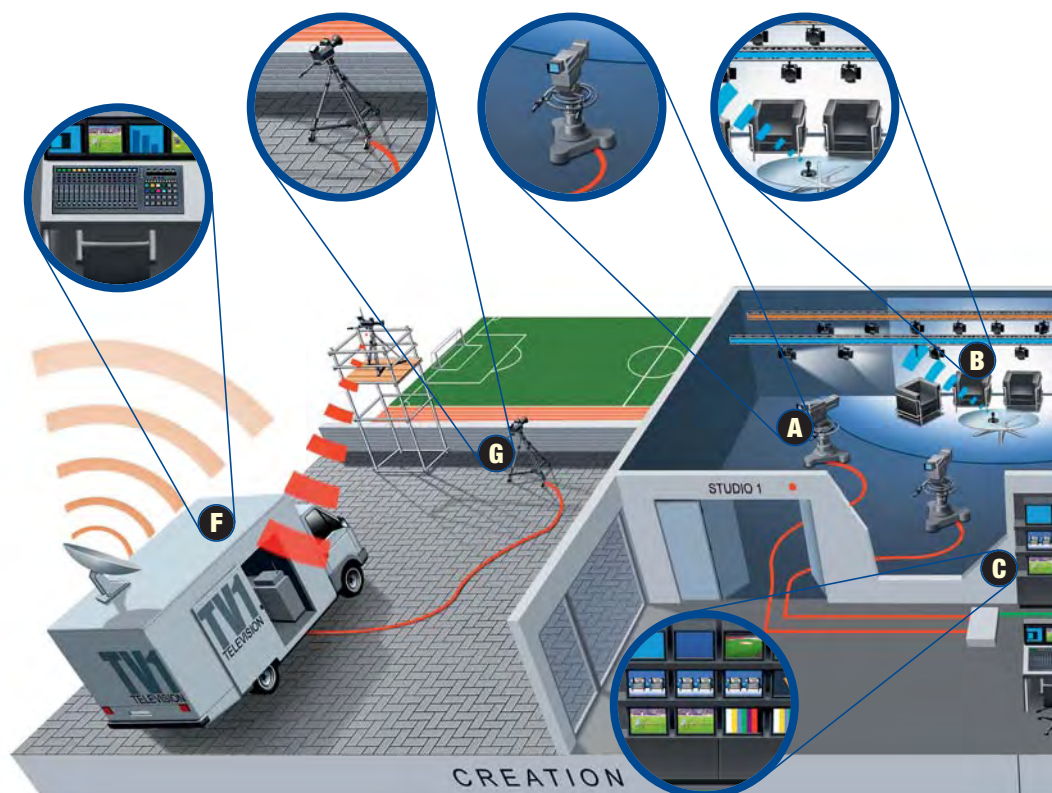



B Audio

Audio Connect Cable

- Single and multi-pair designs for studio and stage applications
- Beldfoil® bonded-to-jacket, easy & fast installation
- Foamed dielectrics give a capacitance as low as 43 pF/m, that provides exceptional crush resistance
- AES/EBU digital transmission, Datalene® insulation, 110 Ω +/-10%



Microphone Cable

- Ruggedness, flexibility
- High-conductivity (oxygen-free) ETP copper conductors
- Lie flat on stage or on studio floors
- Long flex life
- Available in 10 colors



C Video

HD Coax Cable

- HD designed; usable for 3 Gb/s (1080p)
- Guaranteed return loss performance
- Installable Performance™
- Crush resistant dielectric
- Bundled versions available in two designs: Videoflex®, Banana Peel®
- 100% Duofoil® and 95% braid coverage



D Lighting Control

DMX512 Cable

- 120 Ω and twisted pairs
- EIA-422/EIA-485-A usage



E RGB and Data

NanoSkew® Cables

- UTP category design
- Ultimate in low skew delivery (>2.2 nsec/100 m)
- VideoTwist® Cat. 5e and Cat. 6 (>9 nsec/100 m).
- Shielded version available



F Mobile Audio/Video and Data (Copper)

CatSnake® Mobile Cat. 5e Cable

- 1-Cat 5e and 4-Cat 5e design
- Supports CobraNet™, EtherSound™, Roland's DigitalSnake™
- Bonded-pair, stranded, heavy duty jacket
- Extremely rugged for any type of tactical, field deployable A/V or data installation
- Unshielded and shielded twisted pairs



G Mobile Audio/Video and Data (Fiber)

TAC Fiber Cable

- Bend-insensitive fiber
- Core-bonded, much better pulling tension
- Low memory effect
- Extremely strong, lightweight, and rugged design
- Single-Mode and Multi-Mode design



H Backbone & Horizontal Cabling

Optical Fiber Cable

- Single- and Multimode designs up to 10 Gb
- Excellent strippability (100 cm)
- 1-432 fiber counts, halogenfree
- FiberExpress® Pre-Connectorized Assemblies



Copper Cable

- DataTwist™ unshielded data cables as Cat. 5e, 6 and 6a
- Bonded-Pair delivers installable performance
- DataTwist™ shielded data cables as Cat. 5e, 6 and 7
- PVC and halogenfree designs
- GigaFlex™ patch cords Cat.6

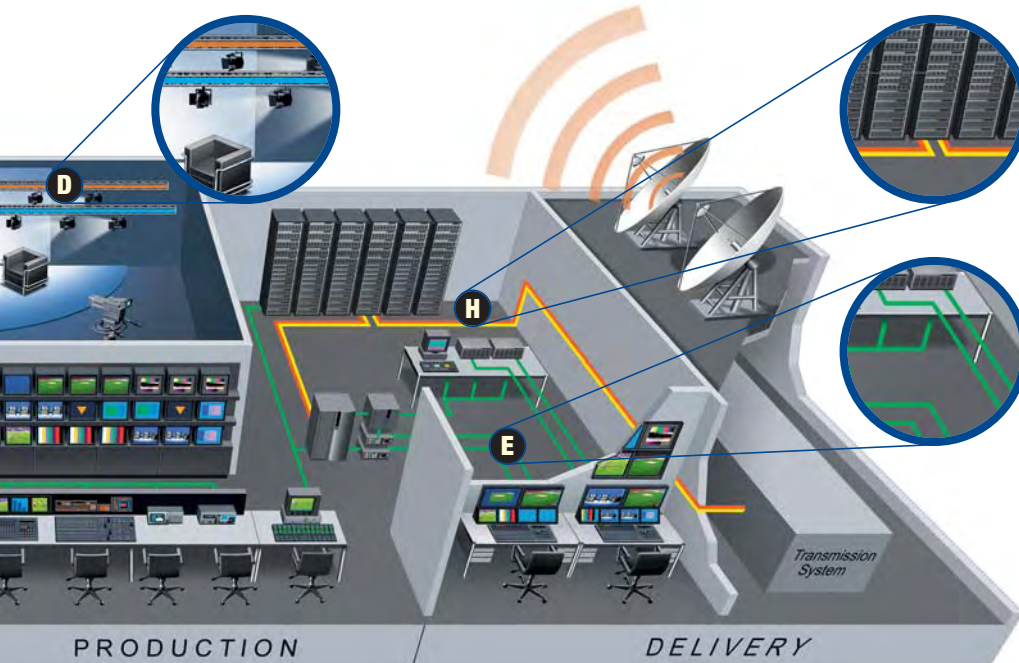

Professional Audio & Video

Cost efficient and high quality infrastructure solutions for a wide range of applications that require a professional approach.

Versatile and Value-added

For decades, Belden® has been the number one choice for professionals working with a wide range of audio visual applications. Customers in the public A/V and live performance market, appreciate the wide choice, high standards and added value that Belden can bring to their systems in terms of quality and reliability.

The Highest Standards

In today's electronic age, there is a growing demand for high performance audio/visual communications. There is a need for professional quality audio/video cabling systems and components, ranging from relatively simple to highly sophisticated, integrated broadband and multimedia solutions. Belden is the one cabling manufacturer with the innovative products, technical expertise and worldwide distribution network capable of fulfilling these requirements.





A Audio

Microphone Cables

- Ruggedness, flexibility
- Oxygen-free copper conductors

Audio Cables

- Single and multi-pair designs
- Individually shielded & jacketed pairs
- Overall Beldfoil® shield
- AES/EBU digital transmission



Loudspeaker Cables

- Most common gage selection depending on the speaker impedance and acceptable power loss
- Halogenfree designs for in- and outdoor usage



B Video

System Integrator Digital Coax Cables

- HD designed; sweep tested to 3 GHz
- Foil is placed over the braid and securely bonded to the jacket so it is self-removing during cable preparation
- Foil shield that is securely bonded to the jacket and is self-removing during preparation for connection thus making installation easier and eliminating the risk of foil stringers and shorting
- Gas-injected foam HD polyethylene dielectric
- 100% Duofoil® and 85% braid coverage



C TV

HDMI Cables

- Version 1.3b, "Eye-pattern" tested, 1080i/1080p
- 5 standard lengths: 1, 2, 3, 4, 7 m



D Multimedia Control

1502R Cable

- Beldfoil®, stranded
- Supports Extron®, AMX AxLink™ and Lutron systems



E Projector, Beamer, Plasma/LED Screens

Hybrid Cables

- Shielded twisted pair audio & video mini-RG59
- Banana Peel® design



S-VHS, S-Video Cables

- 2 x 1865A design
- Fits standard BNC connector



F Home Office, Control, Automation

Composite Cables

- Data, audio, video, security and control hybrid designs
- Banana Peel® design – jacketless Cables



G Security and Alarm

New Generation® Cables

- Multiconductor and coaxial designs
- PVC and halogenfree designs for in- and outdoor usage



Data Center

Flexible and Future-proof

Helping to achieve maximum uptime in both privately owned and managed data centers from the first company to introduce 10G systems.

The Data Center has become a critical asset for many organizations, from financial institutions, universities and commercial companies to large manufacturers. To ensure the best performance, now and in the future, the structured cabling system has to be scalable, flexible and durable. With decades of experience, Belden® is able to meet even the most demanding cabling and connectivity needs, offering the best performance, now and in the future. Belden's IBDN System offers the right solution and with a full 25 year warranty ensures that the Data Center will keep performing.



Future-proof

With ever-increasing bandwidth requirements, Data Centers are moving towards 10Gb equipment. As the leader in this field, Belden was the first to introduce a 10GB system with margin to spare – Belden's 10GX IBDN system performs to 625 MHz, well above the standard requirement. Belden's fiber solutions such as the FiberExpress® Ultra Patch Panel System provide an answer to even the most demanding requirements of the modern Data Center.



A Main Distribution Area (MDA) Horizontal Distribution Area (HDA)

- 10GX® System including Ultra High-density Patch Panels and Cords
- Category 6+ IBDN 4800 System
- Category 6 IBDN 2400 System
- FiberExpress® Systems
- FiberExpress® Ultra Patch Panel System
- High Density Racking
- Enclosures
- Adaptive Enclosure Heat Containment

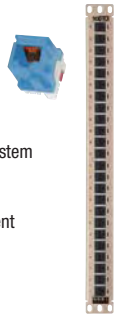

B Equipment Distribution Area (EDA)

- FiberExpress® Systems
- FiberExpress® Ultra Patch Panel System
- 10GX® System including Ultra High-density Patch Panels and Cords
- Category 6+ IBDN 4800 System
- AngleFlex™ Patch Panel
- High Density Racking
- Enclosures
- Adaptive Enclosure Heat Containment



D Entrance Room/ Telecommunication Room (TR)

- FiberExpress® Systems
- FiberExpress® Ultra Patch Panel System
- High Density Racking
- GigaBIX® and 10GX IDC Systems
- 735 and 734 Series Coax Cables
- Enclosures



E Support Offices & Open Area

- Surveillance (CCTV) Camera Cable
- IBDN Cable
- Access Control & Intruder Alarm Cable
- Audio & Video Cables
- Building Control Cables



C Storage Area Network (SAN)

- FiberExpress® Systems
- FiberExpress® Ultra Patch Panel System
- FiberExpress® pre-terminated MPO assemblies
- FiberExpress® Secure Keyed
- High Density Racking
- Enclosures
- Adaptive Enclosure Heat Containment



F Zone Distribution Area (ZDA)

- 10GX® System including Ultra High-density Patch Panels and Cords
- Category 6+ IBDN 4800 System
- GigaBIX® and 10GX IDC System
- High Density Racking
- Enclosures



G Backbone & Horizontal Cabling

- Multimode Fiber Cables
- Singlemode Fiber Cables
- FiberExpress® MPO Cables
- 10 Gigabit 4-pair UTP
- 10GX® RoundFlex Cables
- Category 6+ Cables – Belden's DataTwist® 4800
- Category 6 Cables – DataTwist® 2400

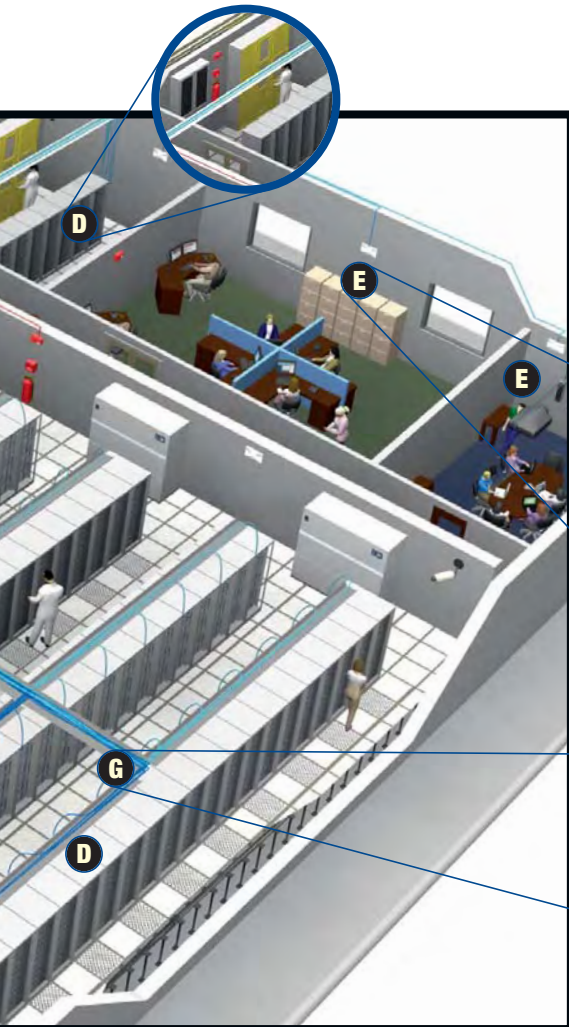

Belden offers the highest levels of technical support and a range of services to help you maximize your investment.

Service Overview

Belden® for Complete Solutions

No solution is complete without the highest levels of support. In addition to its top-performance product offering, Belden has its own highly specialized and flexible support teams. They make sure that your system is functioning perfectly from day one – and that it stays that way. Whether you need long-term technical advice or short-term troubleshooting, Belden is there to provide the right support, around the clock, around the globe.

Network Design

The correct configuration of a network or the optimisation of an existing network is more than a question of technology. Efficient network design is a matter of proper assessment, making the right choices and evaluation of key data and requirements. Belden will support you during system evaluation and technology selection, prepare migration concepts, and provide advice on the use of suitable management tools. From the analysis of your existing network to the evaluation of available technology, we will help you make an informed choice and design the best working solution.

Project Management, Testing and Maintenance

Belden is able to deliver professional implementation. Our specialist support team will not only design your system, but will also assist you with co-ordination, tests and technical documentation, or if you prefer, provide you with a turn-key solution, so that you can concentrate on your day-to-day business. Furthermore, after your system has been installed, Belden will support you to ensure optimum levels for critical elements like performance, security, speed and efficiency. Belden can provide a wide range of further testing and maintenance services – specifically tailored to meet your exact requirements.

Customized Training

If you need to fill knowledge gaps or require employees to be trained on your network, Belden can provide customised training: either at one of our dedicated Training Centers, or at your own premises.



The Belden Competence Center

As the use and complexity of connectivity solutions have increased, so has the pressures on users to design, implement and maintain them. From plant-level Ethernet networks to Building Management Systems and from Data Centers to Broadcast Studios – all installations and applications require highly sophisticated installation, as well as complex operations and processes.

The Belden Competence Center offers access to unrivalled experience and technical support. Our staff has extensive hands-on experience in designing, installing and using solutions created with our range of Belden®, Hirschmann™ and Lumberg Automation™ products.

Each member of Belden's service team has their own field of technical expertise, ensuring that customers get the very best assistance and support.

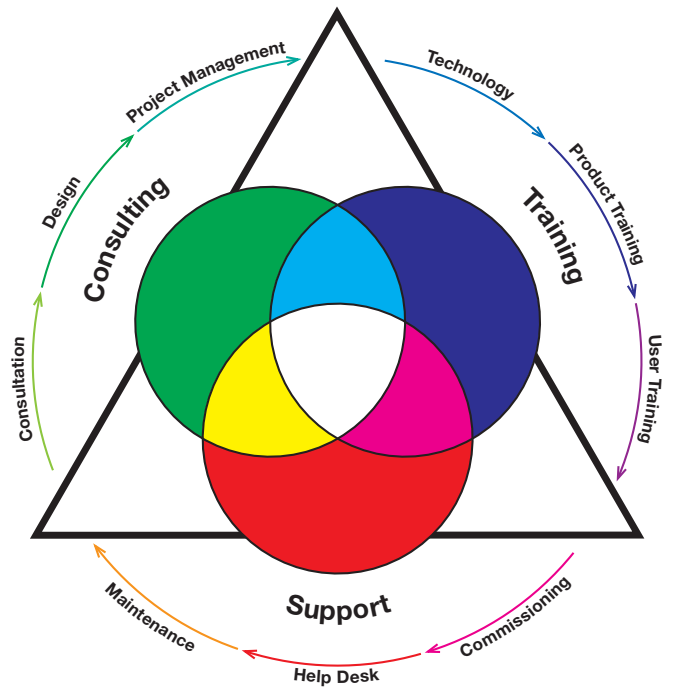

What we can do for you – and how

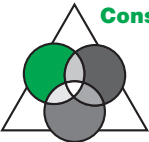
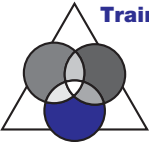
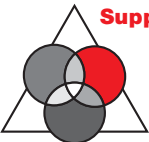
	Optimal Network Solution	Know-how for Reliable Operation	Protection Against Downtimes	Lasting Cost Control
 Consulting	<ul style="list-style-type: none"> Individual consultation, design, project management Network design and migration concepts Compatibility testing On-site wireless site survey 	<ul style="list-style-type: none"> Training plans Documentation Maintenance concepts Security concepts (network security) 	<ul style="list-style-type: none"> Integration of redundancy Spare parts store concept Emergency concepts 	<ul style="list-style-type: none"> Service planning Complete costing
 Training	<ul style="list-style-type: none"> Technology and product training courses for network designers Introduction courses for decision makers 	<ul style="list-style-type: none"> Individual user training courses Security training Workshops 	<ul style="list-style-type: none"> Qualification/certification of your employees and external service providers 	<ul style="list-style-type: none"> Update training for technologies and product
 Support	<ul style="list-style-type: none"> Pre-configuration and pre-assembly of systems On-site commissioning Application tests 	<ul style="list-style-type: none"> Network monitoring and support by in-house experts or partners Network security audit Network baselining 	<ul style="list-style-type: none"> 24x7 support hotline On-site support Remote service Replacement hardware services 	<ul style="list-style-type: none"> Warranty extension Individual, product-related service packages

Hirschmann™ – The Technology and Market Leader in Industrial Networking

Hirschmann™ has adopted a major role in the establishment of Ethernet technology as the standard in the production area.

As specialist for automation and networking technology, Hirschmann™ develops innovative solutions, which are geared towards its customers' requirements in terms of performance, efficiency and investment reliability.

Hirschmann™ has adopted a major role in the establishment of Ethernet technology as the standard in the production area. Today, the Powerlink protocol from the Ethernet Powerlink Standardization Group already provides an open method for the realisation of hard realtime applications using Ethernet, for example for machinery controllers by integrating the CANopen® Protocols. Hirschmann™ is a founding member of the EPSG.

It is currently the only brand on the market to offer a complete product range for homogeneous data communication in the industrial sector using Ethernet and Fieldbus systems. This includes Layer 2 and Layer 3 switches as well as industrial security and WLAN systems that provide a uniform, company-wide communications infrastructure without interface problems and media discontinuities. These products are used in many different applications such as factory automation, process control, transportation and mechanical engineering.

Hirschmann™ not only offers a complete range of products for company-wide data networks, but also a broad support package direct from the product manufacturer. Customers are supported, both during the conception of tailor-made communications solutions, and during the planning, design, commissioning and maintenance of the networks. Seminars and workshops, in which trends and developments are evaluated, and technical subjects put into practice, complete the range of services.





Table of Content	Page
Unmanaged DIN Rail Mount Switches	30–32
Entry-level Unmanaged Switches – SPIDER Family	30
Feature-rich Unmanaged RS2 Switches	31
OpenRail RS20/RS30 Unmanaged Switches	32
RSB – Basic Switch Line	33
Cost-effective Fast Ethernet Switches	33
Managed DIN Rail Mount Switches	34–38
OpenRail Concept	34
RSR Compact Ruggedized Switches	36
Modular MICE Switches	36
PowerMICE – Powerful and Feature-rich Gigabit Layer 2/3 Switches	37
MICE Media Modules	38
IP67 Switches	39
OCTOPUS IP67 Switches	39
Rack Mounted Switches	40–42
MACH1000 19" Ruggedized Switches	40
MACH4000 Gigabit Backbone Layer 2/3 Switches	41
MACH4000 Media Modules	42
Workgroup Switches	43–44
MACH100 Industrial Workgroup Switches	43
PowerLION	44
Software Functionality	45
Switch and Network Management	46–47
Industrial Profiles EtherNet/IP and PROFINET	46
Field Device Tool	46
HiVision Management Software	46
Industrial HiVision Network Visualization Software	47
BAT Wireless Access Points, Clients and Bridges	48–49
BAT54-Rail, BAT300-Rail, BAT54-F, BAT300-F	48
Antennas	49
Accessories	49
Security	50
EAGLE20 Firewall/VPN Router	50
Transceivers and FiberINTERFACES	51
Rail Transceivers and Hubs	51
FiberINTERFACES/Universal Fiber Optic Transceivers	51
FiberINTERFACES / Fieldbus Repeaters	52
Profibus, Genius, Modbus and WorldFIP	52
Accessories	53
SFPs + XFD Modules, Power Supplies, 19" DIN Rail Adapter	
Programming and Configuration Backup	53

Unmanaged DIN Rail Mount Switches



Entry-level Unmanaged Switches – SPIDER Family

The SPIDER family of switches provides users with an economical, yet highly reliable Ethernet switch. All copper/RJ45 ports are 10/100 auto-negotiating and auto-crossing – the SPIDERS will work with either patch or cross-over cables. The fiber ports are all 100 Mbps and available in multimode (MM) and singlemode (SM) with either SC or ST sockets.

Standard features include:

- 0°C up to +60°C operating range
- 24 VDC power input via pluggable terminal block
- Average MTBF (Mean Time Between Failure) exceeding 100 years

All Copper/RJ45

- | | | | |
|------------------|----------|---------------------|----------|
| • SPIDER 3TX-TAP | 3 x RJ45 | • SPIDER II 8TX | 8 x RJ45 |
| • SPIDER 5TX | 5 x RJ45 | • SPIDER II 8TX EEC | 8 x RJ45 |
| • SPIDER 5TX EEC | 5 x RJ45 | | |

Copper/RJ45 and Fiber

- | | |
|----------------------------|-------------------------|
| • SPIDER 4TX/1FX | 4 x RJ45 and 1 x MM, SC |
| • SPIDER 4TX/1FX EEC | 4 x RJ45 and 1 x MM, SC |
| • SPIDER 4TX/1FX-ST EEC | 4 x RJ45 and 1 x MM, ST |
| • SPIDER 4TX/1FX SM EEC | 4 x RJ45 and 1 x SM, SC |
| • SPIDER 1TX/1FX | 4 x RJ45 and 1 x MM, SC |
| • SPIDER 1TX/1FX EEC | 4 x RJ45 and 1 x MM, SC |
| • SPIDER 1TX/1FX-SM | 4 x RJ45 and 1 x MM, SC |
| • SPIDER 1TX/1FX SM EEC | 4 x RJ45 and 1 x SM, SC |
| • SPIDER II 8TX/1FX EEC | 8 x RJ45 and 1 x MM, SC |
| • SPIDER II 8TX/1FX-ST EEC | 8 x RJ45 and 1 x MM, ST |
| • SPIDER II 8TX/2FX EEC | 8 x RJ45 and 2 x MM, SC |
| • SPIDER II 8TX/2FX-ST EEC | 8 x RJ45 and 2 x MM, ST |
| • SPIDER II 8TX/1FX-SM EEC | 8 x RJ45 and 1 x SM, SC |
| • SPIDER II 8TX/2FX-SM EEC | 8 x RJ45 and 2 x SM, SC |
| • SPIDER II 8TX/PoE | 4 x RJ45 and 4 x PoE |

Full Gigabit

- | | |
|----------------------------|---|
| • SPIDER II Giga 5T EEC | 5 x RJ45 (10/100/1000) |
| • SPIDER II Giga 5T/2S EEC | 5 x RJ45 (10/100/1000), and 2 x SFP Slot (1000) |

EEC stands for extended environmental conditions (-40°C up to + 70°C)



Unmanaged DIN Rail Mount Switches



Feature-rich Unmanaged Switches – RS2 Switches

These switches offer advanced features such as redundant power inputs and most offer fault relay (triggerable by loss of power and/or port-link).

Standard features include:

- 10/100 auto-negotiating and auto-crossing (either patch or cross-over cables will work in the ports)
- 0°C up to +60°C operating range
- 24 VDC power input via pluggable terminal block
- Average MTBF (Mean Time Between Failure) exceeding 100 years

All of the multimode (MM) and singlemode (SM) fiber optic ports are 100 Mbps and are available in a variety of connector options.

All Copper/RJ45

- RS2-4TX EEC* 4x10/100 Mbps RJ45, link loss alarm, power loss alarm
- RS2-5TX 5x10/100 Mbps RJ45, rugged die-cast metal housing offering wall-mount option
- RS2-TX 8x10/100 Mbps RJ45, link loss alarm, power loss alarm, fault relay output

All Copper/RJ45

- RS2-3TX/2FX EEC* 3x10/100 Mbps RJ45 and 2x100 MbpsMM-SC, link loss alarm, power loss alarm
- RS2-3TX/2FX-SM EEC* 3x10/100 Mbps RJ45 and 2x100 MbpsSM-SC, link loss alarm, power loss alarm
- RS2-5TX/FX** 4x10/100 Mbps RJ45 and 1x100 MbpsMM-MTRJ, rugged die-cast metal housing
- RS2-4TX/1FX EEC* 4x10/100 Mbps RJ45 and 1x100 MbpsMM-SC, link loss alarm, power loss alarm
- RS2-4TX/1FX-ST EEC* 4x10/100 Mbps RJ45 and 1x100 MbpsMM-ST, link loss alarm, power loss alarm
- RS2-4TX/1FX-SM EEC* 4x10/100 Mbps RJ45 and 1x100 MbpsSM-SC, link loss alarm, power loss alarm

* Fault relay output, extended temperature -40°C up to +70°C

** Offering wall-mount option

OpenRail Unmanaged DIN Rail Mount Switches



RS20 and RS30 Unmanaged Switches

Hirschmann™'s unmanaged OpenRail switches are ideal for applications that are less dependent upon the features of switch management while maintaining the highest feature-set for an unmanaged switch.

Standard features include:

- 8x, 9x, 16x, 17x, 24x and 25x ports in a maximum footprint
- Up to 4x fiber ports
- Redundant power inputs via dual 24 VDC
- Fault relay (triggerable by loss of one power input and/or the loss of one of the links specified)
- 10/100/1000 auto-negotiating and auto-crossing (either patch or crossover cables will work in the ports)
- Variety of connector options for Multimode (MM) and Singlemode (SM) fiber optic ports
- Choice of operating temperatures and conformal coating (standard is 0°C up to +60°C, -40°C up to +70°C is also available)
- Variety of approvals including IEC 61850-3, IEEE 1613, EN 50121-4 and ATEX 100a Zone 2

All Copper/RJ45

- RS20-1600T1T1SDAU 16x10/100 Mbps RJ45

Multimode

- RS20-0900NNM4TDAU 3x100 Mbps MM fiber (ST) and 6x10/100 Mbps RJ45
- RS20-0900MMM2TDAU 3x100 Mbps MM fiber (ST) and 6x10/100 Mbps RJ45
- RS20-1600M2T1SDAU 1x100 Mbps MM fiber (SC) and 15x10/100 Mbps RJ45
- RS20-1600M2M2SDAU 2x100 Mbps MM fiber (SC) and 14x10/100 Mbps RJ45
- RS20-1600S2M2SDAU 1x100 Mbps MM fiber (SC), 1x100 Mbps SM fiber (SC) and 14x10/100 Mbps RJ45
- RS20-1600L2M2SDAU 1x100 Mbps MM fiber (SC), 1x100 Mbps Long Haul SM fiber (SC) and 14x10/100 Mbps RJ45

Singlemode

- RS20-0900VVM2TDAU 3x100 Mbp SM fiber (SC) and 6x10/100 Mbps RJ45
- RS20-1600S2T1SDAU 1x100 Mbps SM fiber (SC) and 15x10/100 Mbps RJ45
- RS20-1600S2S2SDAU 2x100 Mbps SM fiber (SC) and 14x10/100 Mbps RJ45
- RS20-1600L2T1SDAU 1x100 Mbps Long Haul SM fiber (SC) and 15x10/100 Mbps RJ45
- RS20-1600L2S2SDAU 1x100 Mbps Long Haul SM fiber (SC) 1x100 Mbps SM fiber (SC) and 14x10/100 Mbps RJ45
- RS20-1600L2L2SDAU 2x100 Mbps Long Haul SM fiber (SC) and 14x10/100 Mbps RJ45
- RS20-1600S2M2SDAU 1x100 Mbps MM fiber (SC), 1x100 Mbps SM fiber (SC) and 14x10/100 Mbps RJ45
- RS20-1600L2M2SDAU 1x100 Mbps MM fiber (SC) 1x100 Mbps Long Haul SM fiber (SC) and 14x10/100 Mbps RJ45

Part Number Configurator

Design	Ports FE	Ports GE	Uplink port 1	Uplink port 2	Temp. range	Power supply	Ap-provals	Software version
RS20-	08	00	S2	S2	T	D	H	U

Due to the vast number of switch variations (port density, port type, approvals, power input, etc.), Hirschmann™ has developed a part number matrix that permits users to customize their own switch. Simply decide on Compact or Modular, number of ports, the type of uplink ports (these can be used as standard ports), and select the temperature, power and approvals. The configurator can be found at: www.beldensolutions.com/configurator



RSB – Basic Switch Line



Cost-effective Fast Ethernet Switches

The best solutions are usually the most simple ones. In practical industrial Ethernet applications, users of high performance, intelligent power switches may also be looking for minimal management, and more limited software functions compared to the enhanced and professional versions of the OpenRail range. To meet this need, Hirschmann™ has introduced the RSB20 Basic Switch line.

These Basic Switches provide the necessary functions: management and full redundancy at a cost-effective price. This enables users to create redundant networks and capture diagnostic data from the network.

Standard features include:

- 8 and 9-port Fast Ethernet Entry Level managed Switches
- Designed for reliable transfer of diagnostic data
- HIPER-Ring, MRP, RSTP and redundant ring coupling
- Standard 0°C up to +60°C (-40°C up to +70°C available)
- Compatible with PROFINET and EtherNet/IP
- Web-based configuration and management
- Maximum cost effectiveness

• RSB20-0800T1T1SAABHH	8 TX*
• RSB20-0800M2M2SAABHH	6Tx; 2FX MM DSC*
• RSB20-0800S2S2SAABHH	6Tx; 2FX SM DSC*
• RSB20-0900ZZZ6SAABHH	6Tx; 3 SFP slots*
• RSB20-0900M2TTAABHH	8Tx; 1FX MM DSC*
• RSB20-0900S2TTAABHH	8Tx; 1FX SM DSC*
• RSB20-0900MMM2SAABHH	6Tx; 3FX MM DSC*
• RSB20-0900VVM2SAABHH	6Tx; 2FX SM DSC; 1FX MM DSC*

* Also versions with extended temperature range from -40°C up to +70°C are available ("T" version)

Managed DIN Rail Mount Switches



OpenRail Compact and Modular Switches

With the continued growth and demand for application-specific switches, Hirschmann™ has developed the OpenRail line of managed and unmanaged switches. The OpenRail series allows users to choose either a Compact or Modular switch, as well as specify port density, backbone type (RJ45/fiber) and speed, temperature ratings, conformal coating and a wide range of industry standards. Both the compact and modular platforms offer redundant power inputs and fault relay (triggerable by loss of power and/or port link), while only the managed version offers media/ring redundancy, multicast filtering/IGMP Snooping, VLAN, port mirroring, network diagnostics, port control, etc.

Compact Switches

A compact platform that allows for up to 24-ports in a mere 12 cm of DIN rail. Available in managed and unmanaged versions (only the RS20-04 switch is not available in an unmanaged version).

- RS20 Available as a managed and unmanaged switch, 4x, 8x, 9x, 16x, 17x, 24x and 25x10/100 Mbps ports
- RS30 Available as a managed and unmanaged switch, 2x Gigabit Uplinks and 8x, 16x and 24x10/100 Mbps ports
- RS40 Only available as a managed switch, 9x Gigabit ports

Modular Switches (MICE series)

A modular and flexible platform that facilitates an almost limitless variety of port variations while allowing users to change the switch's port density and configuration on the fly using hot-plug Media Modules (see page 38). Only available as a managed switch.

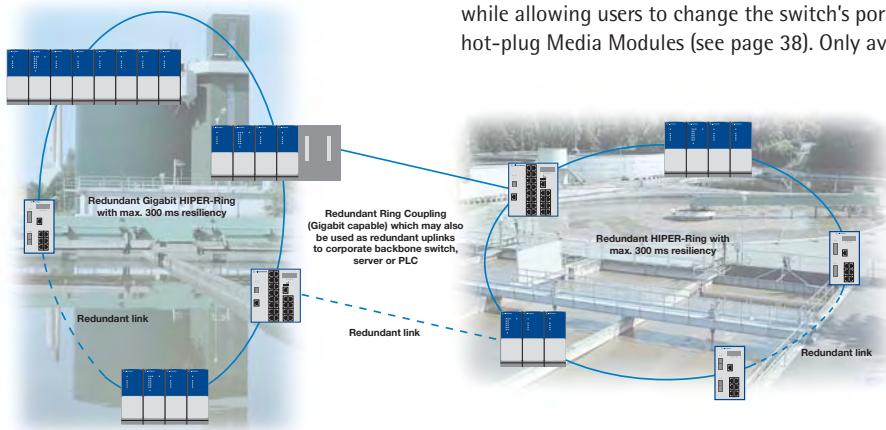

- MS20-08 8x10/100 ports max
- MS20-16 16x10/100 ports (24x10/100 max with backplane extension)
- MS30-08 2x Gigabit and 8x10/100 ports max
- MS30-16 2x Gigabit and 16x10/100 ports (24x10/100 max with backplane extension)
- MS4218 (PowerMICE) 4x Gigabit and 16x10/100 ports (24x10/100 max with backplane extension), Layer 3/routing switch version available

Part Number Configurator

Design	Ports FE	Ports GE	Temp. range	Power supply	Ap-provals	Software version	Configu-ration	OEM-Type	Software release
MS20-	08	00	S	A	A	E	H	H	04.0.

Due to the vast number of switch variations (port density, port type, approvals, power input, etc.), Hirschmann™ has developed a part number matrix that permits users to customize their own switch. Simply decide on Compact or Modular, number of ports, the type of uplink ports (these can be used as standard ports), and select the temperature, power and approvals. The configurator can be found at: www.beldensolutions.com/configurator



RS20 Compact Switches

All copper ports are 10/100 Mbps, uplink ports are 100 Mbps

Standard features include:

- Available in 4/8/9/16/17/24 and 25x100 Mbps ports
- Fully managed (web, SNMP and CLI) – VLAN, IGMP snooping (multicast filtering), port mirroring, port control, port security, link alarms, broadcast limiter, traffic diagnostics, ring redundancy and much more
- Fiber ports are available in multimode and/or singlemode
- Dual power inputs and fault relay
- USB port for configuration backup/restore and fast device replacement
- Std. 0°C up to +60°C (-40°C up to +70°C and conformal coating avail.)
- Differentiator between similar switches listed is the firmware level/features. See www.beldensolutions.com/configurator

All Copper			
• RS20-0400T1T1SDAE	4x RJ45	• RS20-1600T1T1SDAE	16x RJ45
• RS20-0400T1T1SDAP	4x RJ45	• RS20-1600T1T1SDAP	16x RJ45
• RS20-0800T1T1SDAE	8x RJ45	• RS20-2400T1T1SDAE	24x RJ45
• RS20-0800T1T1SDAP	8x RJ45	• RS20-2400T1T1SDAP	24x RJ45

Multimode			
• RS20-0400M2T1SDAE	3x RJ45, 1x SC	• RS20-0800M4M4SDAP	6x RJ45, 2x ST
• RS20-0400M2T1SDAP	3x RJ45, 1x SC	• RS20-1600M2T1SDAE	15x RJ45, 1x SC
• RS20-0400M2M2SDAE	2x RJ45, 2x SC	• RS20-1600M2T1SDAP	15x RJ45, 1x SC
• RS20-0400M2M2SDAP	2x RJ45, 2x SC	• RS20-1600M2M2SDAE	14x RJ45, 2x SC
• RS20-0800M2M2SDAE	6x RJ45, 2x SC	• RS20-1600M2M2SDAP	14x RJ45, 2x SC
• RS20-0800M2M2SDAP	6x RJ45, 2x SC	• RS20-2400M2M2SDAE	22x RJ45, 2x SC
• RS20-0800M4M4SDAE	6x RJ45, 2x ST	• RS20-2400M2M2SDAP	22x RJ45, 2x SC

Singlemode			
• RS20-0400S2T1SDAE	3x RJ45, 1x SC	• RS20-0800S2S2SDAP	6x RJ45, 2x SC
• RS20-0400S2T1SDAP	3x RJ45, 1x SC	• RS20-1600S2S2SDAE	14x RJ45, 2x SC
• RS20-0400S2S2SDAE	2x RJ45, 2x SC	• RS20-1600S2S2SDAP	14x RJ45, 2x SC
• RS20-0400S2S2SDAP	2x RJ45, 2x SC	• RS20-2400S2S2SDAE	22x RJ45, 2x SC
• RS20-0800S2S2SDAE	6x RJ45, 2x SC	• RS20-2400S2S2SDAP	22x RJ45, 2x SC

Add an "E" to all-copper 4, 8, 16 and 24 port switches for pre-configured IGMP Snooping, auto-negotiation on the uplinks and more (a factory-set configuration for EtherNet/IP). Contact us for more details.

Part Number Configurator

Due to the vast number of switch variations (port density, port type, approvals, power input, etc.), Hirschmann™ has developed a part number matrix that permits users to customize their own switch. Simply decide on Compact or Modular, number of ports, the type of uplink ports (these can be used as standard ports), and select the temperature, power and approvals.



RS30 Compact Switches

All copper ports are 10/100 Mbps, uplink ports are Gigabit

Standard features include:

- Available with 8x, 16x and 24x 10/100 Mbps ports with 2 additional Gigabit ports
- Identical management and features as RS20
- Fiber uplink ports are available in multimode and/or singlemode by using Gigabit SFP

All Copper	
• RS30-0802T1T1SDAE	8x10/100 RJ45, 2x10/100/1000 RJ45
• RS30-0802T1T1SDAP	8x10/100 RJ45, 2x10/100/1000 RJ45
• RS30-1602T1T1SDAE	16x10/100 RJ45, 2x10/100/1000 RJ45
• RS30-1602T1T1SDAP	16x10/100 RJ45, 2x10/100/1000 RJ45
• RS30-2402T1T1SDAE	24x10/100 RJ45, 2x10/100/1000 RJ45
• RS30-2402T1T1SDAP	24x10/100 RJ45, 2x10/100/1000 RJ45

Fiber	
• RS30-08020606SDAE	8x10/100 RJ45, 2x Gigabit SFP
• RS30-08020606SDAP	8x10/100 RJ45, 2x Gigabit SFP
• RS30-16020606SDAE	16x10/100 RJ45, 2x Gigabit SFP
• RS30-16020606SDAP	16x10/100 RJ45, 2x Gigabit SFP
• RS30-24020606SDAE	24x10/100 RJ45, 2x Gigabit SFP
• RS30-24020606SDAP	24x10/100 RJ45, 2x Gigabit SFP

RS40 Compact Switches

All ports are Gigabit



Standard features include:

- Available with 9 ports (4 of which are combo ports)
- Identical management and features as RS20 and RS30
- 9x 10/100/1000 RJ45 and 4x RJ45/SFP combo ports (function of one RJ45 is lost for each SFP utilized)
- Fiber uplink ports are available in multimode and/or singlemode by using Gigabit or 100 Mbps SFP

• RS40-0009CCCCSDAE	4x100/1000 SFP
• RS40-0009CCCCSDAP	4x100/1000 SFP

A combo port is a 10/100/1000 Mbps RJ45 and 1000 Mbps SFP. The use of one SFP port disables one RJ45 port. The use of two SFP ports disables two RJ45 ports, etc. for a maximum of 4 ports.

The configurator can be found at: www.beldensolutions.com/configurator

Design	Ports FE	Ports GE	Uplink port 1	Uplink port 2	Temp. range	Power supply	Ap-provals	Software version
RS20-	24	00	M2	T1	S	D	A	U

Managed DIN Rail Mount Switches



Fast
HIPER-Ring

RSR Compact Ruggedized Switches

RSR-XX Ruggedized Gigabit Ethernet switches for DIN rail

Standard features include:

- -40°C up to +85°C temperature range
- Up to two AC/DC inputs with choice of voltage
- DIN rail or panel mounting
- Extremely high RFI/EMI immunity
- Robust metal housing
- Withstand tremendous shocks and vibrations
- From 8TX up to 10 ports fiber
- Panel mount kit available
- Ultra-fast ring recovery time <10ms



Switch MS20-08 Switch MS20-16

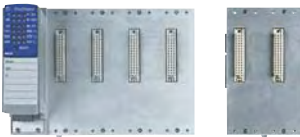

Switch MS20-24 (including backplane extension MB-2T)



Switch MS30-08 Switch MS30-16



Switch MS30-24 (including backplane extension MB-2T)



Switch MS4128-Lxx



Backplane extension MB-2T

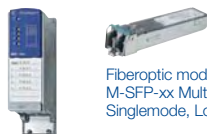

Media modules RJ45, M12, SC, ST, LC Multimode, Singlemode, Long Haul, POF, HCS



Fiber optic module M-SFP-xx Multimode, Singlemode, Long Haul

Part Number Configurator

Design	Ports FE	Ports GE	Uplink port 1	Uplink port 2	Remaining ports	Temp. range	Voltage range 1	Voltage range 2	Approvals	Software version	Configuration	OEM-Type	Software release
RSR30-	08	02	CC	ZZ	T1	U	C	C	H	P	H	H	04.0.

Due to the vast number of switch variations (port density, port type, approvals, power input, etc.), Hirschmann™ has developed a part number matrix that permits users to customize their own switch. Simply decide on Compact or Modular, number of ports, the type of uplink ports (these can be used as standard ports), and select the temperature, power and approvals. The configurator can be found at: www.beldensolutions.com/configurator

MS20 Modular MICE Switches

All ports are 10/100 Mbps

Standard features include:

- Available in a 2- and 4-slot version (slot can be expanded to a 6 slot using MB-2T)
- MS20-08 can have a max of 8x10/100 Mbps ports. MS20-16 can have a max of 16x10/100 Mbps and with MB-2 a max of 24x10/100 Mbps ports
- Requires the use of media modules (see page 38)
- Fully managed (web, SNMP and CLI) – IGMP snooping (multicast filtering), VLAN, port mirroring, port control, port security, link alarms, broadcast limiter, traffic diagnostics, HIPER-Ring redundancy, RSTP, etc.
- Dual power inputs and dual fault relay outputs
- USB port for configuration backup/restore and fast device replacement
- Standard 0°C up to +60°C (-40°C up to +70°C and conformal coating available)
- Differentiator between similar switches listed is the firmware level/features



• MS20-0800SAAE	2x any MM2/MM3 (max 8 ports)
• MS20-0800SAAP	2x any MM2/MM3 (max 8 ports)
• MS20-1600SAAE	4x any MM2/MM3 (max 24 ports), (6x w/MB-2T)
• MS20-1600SAAP	4x any MM2/MM3 (max 24 ports), (6x w/MB-2T)

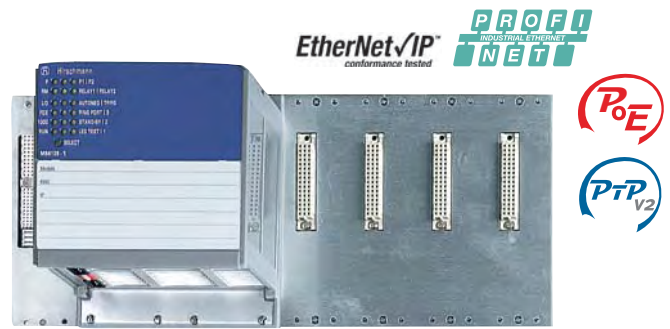
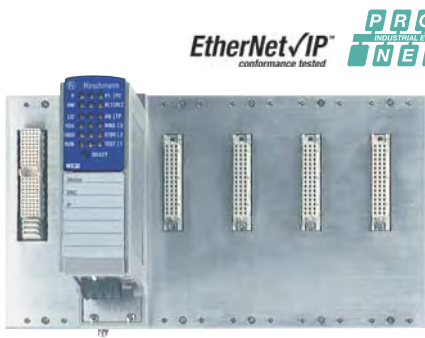

MS30 Modular MICE Switches

Uplink ports are 10/100/1000 Mbps, other ports are 10/100 Mbps

Same functionality and features as MS20, with the exception of an added slot for a Gigabit Media Module (for 2x10/100/1000 Mbps uplinks).

- MS30-08 can have a max of 8x10/100 Mbps ports and 2x10/100/1000 Mbps ports
- MS30-16 can have a max of 16x10/100 Mbps ports and 2x10/100/1000 Mbps ports and with MB-2 a max of 24x10/100 Mbps ports and 2x10/100/1000 Mbps ports

Uplinks may be copper and/or fiber. Fiber is available in multimode and singlemode by using Gigabit or 100 Mbps SFPs.

• MS30-08002SAAE	2x any MM2/MM3 and 1x MM4-2TX/SFP (max 10 ports)
• MS30-08002SAAP	2x any MM2/MM3 and 1x MM4-2TX/SFP (max 10 ports)
• MS30-16002SAAE	4x any MM2/MM3 (6x w/MB-2T) and 1x MM4-2TX/SFP (max 26 ports)
• MS30-16002SAAP	4x any MM2/MM3 (6x w/MB-2T) and 1x MM4-2TX/SFP (max 26 ports)

MS Backplane Extension

MICE Backplane Extension

- **MB-2T**
 - 2-slot backplane extension for MS20-16, MS30-16 and MS4128. Only one per switch for a maximum of six slots to the right of the backplane head module.
- **MB20-2TAHH**
 - Same as above, but with -40°C up to +70°C



PowerMICE

Gigabit Layer 2/3 Switches

For applications that require a more powerful and feature-rich switch, Hirschmann™ offers its PowerMICE modular switches. Similar in functionality and features to the MS30, the PowerMICE adds two additional Gigabit ports (for a total of four) and an option to have Layer 3 routing capabilities.

Please note that Gigabit ports are 10/100/1000 RJ45 with SFP Slots. SFP(s) are needed for fiber functionality – one RJ45 port is lost for every SFP used.

- **MS4128-L2P**
 - MICE, modular, managed Industrial Ethernet Layer 2 Switch with Professional management. Maximum 24x10/100 ports + 4x Gigabit ports (any copper/fiber mix), for a total of 28 ports.
- **MS4128-L3E**
 - MICE, modular, managed Industrial Ethernet Layer 3 Switch with Enhanced management. Maximum 24x10/100 ports + 4x Gigabit ports (any copper/fiber mix), for a total of 28 ports.
- **MS4128-L3P**
 - MICE, modular, managed Industrial Ethernet Layer 3 Switch with Professional management. Maximum 24x10/100 ports + 4x Gigabit ports (any copper/fiber mix), for a total of 28 ports.

Managed DIN Rail Mount Switches



MICE Media Modules

Any combination of the following hot-swappable media modules may be used to attain the desired port density/type on a MICE switch. The only restriction is the number of slots that the MICE has (one media module/slot).

The Maximum Module Density	
<ul style="list-style-type: none"> MS20-08 2x any MM2/MM3 MS20-16 4x any MM2/MM3 (6x MB-2T) MS30-08 2x any MM2/MM3 plus 1x MM4-2TX/SFP 	<ul style="list-style-type: none"> MS30-16 4x any MM2/MM3 (6x MB-2T), plus 1x MM4-2TX/SFP MS4128 4x any MM2/MM3 (6x MB-2T), plus 1x any MM4

SFPs are needed for MM4 fiber functionality (see opp. page).

All Copper	
<ul style="list-style-type: none"> MM2-4TX1 4x10/100 Mbps RJ45 	<ul style="list-style-type: none"> MM2-4TX1-EEC* 4x10/100 Mbps RJ45

Singlemode	
<ul style="list-style-type: none"> MM2-2FXS2 2x100 Mbps SM SC MM3-2FXS2/2TX1 2x100 Mbps SM SC, 2x RJ45 MM3-2FXS2/2TX1-EEC* 2x100 Mbps SM SC, 2x RJ45 MM3-1FXS2/3TX1 1x100 Mbps SM SC, 3x RJ45 MM3-4FXS2 4x100 Mbps SM SC 	<ul style="list-style-type: none"> MM3-1FXL2/3TX1 1x100 Mbps SM, SC Long Haul, 3x RJ45 MM3-1FXS2/3TX1-EEC* 1x100 Mbps SM SC, 3x RJ45 MM3-1FXM2/1FXS2/2TX1 2x100 Mbps SM SC (1x MM and 1x SM), 2x RJ45

Multimode	
<ul style="list-style-type: none"> MM2-4FXM3 4x100 Mbps MM MTRJ MM2-2FXM2 2x100 Mbps MM SC MM3-4FXM2 4x100 Mbps MM SC MM3-4FXM4 4x100 Mbps MM ST MM3-1FXM2/3TX1 1x100 Mbps MM SC, 3x RJ45 MM3-2FXM4/2TX1 2x100 Mbps M ST, 2x RJ45 	<ul style="list-style-type: none"> MM2-2FXM3/2TX1 2x100 Mbps MM MTRJ, 2x RJ45 MM3-4FLM4 4x10 Mbps MM ST MM3-2FXM2/2TX1 2x100 Mbps MM SC, 2x RJ45 MM3-2FXM2/2TX1-EEC* 2x100 Mbps MM SC, 2x RJ45 MM3-1FXM2/1FXS2/2TX1 2x100 Mbps SC (1x MM and 1x SM), 2x RJ45

Gigabit	
<ul style="list-style-type: none"> MM4-2TX/SFP 2x Gigabit RJ45 2 SFP Slots** for MS30 and MS4128 MM4-4TX/SFP 4x Gigabit RJ45 4 SFP Slots** for MS4128 only 	

Special – Technology Modules	
<ul style="list-style-type: none"> MM23-T1T1T1T1SAHH 4x RJ45, IEEE 1588 v 2 realtime modules MM33-07079999SA 2x1000 Mbps SFP Slot, IEEE 1588 v 2 realtime modules MM23-M2M2T1T1SAHH 2x100 Mbps MM SC, 2x RJ45, IEEE 1588 v 2 realtime modules MM23-S2S2T1T1SAHH 2x100 Mbps SM SC, 2x RJ45, IEEE 1588 v 2 realtime modules MM23-F4F4T1T1SAHH 2x10 Mbps MM SC, 2x RJ45, IEEE 1588 v 2 realtime modules MM3-4TX1-RT-EEC 4x RJ45***, IEEE 1588 v 1 realtime modules MM3-2FXM2/2TX1-RT-EEC 2x100 Mbps MM SC, 2x RJ45, IEEE 1588 v 1 realtime modules*** MM3-2FXS2/2TX1-RT-EEC 2x100 Mbps SM SC, 2x RJ45, IEEE 1588 v 1 realtime modules*** MM20-A8A89999SAHH 2x AUI SUB-D, 15-pin male D-sub MM3-4TX5 4x M12 socket (D-code), for connectors see OCTOPUS family on page 39 MM22-T1T1T1T1SAHH 4x RJ45 PoE (external PoE power supply), for accessories see page 53 MM3-1FXLH+/3TX1 1x100 Mbps SM SC Long Haul+, 3x RJ45 MM20-Z6Z6Z6Z6SAHH 4x100 Mbps SFP, for MS20, MS30 and MS4128 	

* EEC media modules have an extended temperature range of -40°C up to +70°C. Additional EEC modules are available. Please consult your Belden representative or www.beldensolutions.com
 ** For every SFP used, one copper port is lost. SFPs need to be purchased separately. See accessories on page 53.
 *** Railway certifications EN 50155, EN 50121-4



IP67 Switches





OCTOPUS IP67 Switches



When space is at a premium and applications demand rugged solutions, OCTOPUS switches offer an ideal solution. These switches are the most robust switches currently on the market and they meet all relevant industry standards. With Power over Ethernet, Hirschmann™ has combined its IP67 solutions with an absolutely future-proof technology. This is deployed in all situations where new applications and end devices such as IP cameras or IP telephones require electrical power without additional installation work. Due to their compact form factor all products in the OCTOPUS family can be mounted on the wall or directly on the machine. The IP67 variants of the proven managed Hirschmann™ switches offer 8/16/24 Twisted Pair ports (each with up to 8 PoE ports), using standardized 4-pin M12 D technology.

These switches can be cascaded freely, making it simple to build decentralized structured networks with the shortest possible patch cables to the end devices. Both the 16- and 24-port versions are also available with two 100BASE-FX uplink ports (microFX).







Standard features include:

- Totally enclosed IP67 design
- ODVA-standardized 4-pin M12 D-code IP67 Ethernet connector
- Fiber optic Gigabit Backbone to the field level
- Management via SNMP v1, v2, v3, web GUI or TELNET
- Redundancy via HIPER-Ring and Rapid Spanning Tree
- Redundant power supply for high availability
- Operating temperatures as low as -40°C up to +70°C
- External signaling of alarms via signal contact or network messaging

OCTOPUS IP67 Connectivity Solutions	
• EM12S 001L0200 OCTOPUS	2 meter patch cord, green, 2x M12
• EM12S 001L0500 OCTOPUS	5 meter patch cord, green, 2x M12
• EM12S 001L1000 OCTOPUS	10 meter patch cord, green, 2x M12
• EM12S OCTOPUS	Field-installable M12 connector 
• EF12RJ45 OCTOPUS	Bulkhead M12 to RJ45 

OCTOPUS IP67 Accessories	
• ACA21-M12 EEC	ACA 21 auto configuration adapter for OCTOPUS managed switches 
• OCTOPUS Terminal Cable	M12 4-pin to Sub-D-9-pin terminal cable
• PC150/36V/48V-IP67	IP67 PoE power supply, input 50.4–154 VDC
• PC150/72V/48V-IP67	IP67 PoE power supply, input 16.8–64 VDC 

OCTOPUS IP67 Switches

• OCTOPUS 5TX EEC	Unmanaged IP67 Switch 5x10/100 Mbps M12-coding 
• OCTOPUS 8M	Managed IP67 Switch 8x10/100 Mbps M12 
• OCTOPUS 8M-Train	Managed IP67 Switch 8x10/100 Mbps M12, EN 50155
• OCTOPUS 16M	Managed IP67 Switch 16x10/100 Mbps M12 
• OCTOPUS 16M-Train	Managed IP67 Switch 16x10/100 Mbps M12, EN 50155
• OCTOPUS 16M-2FX	Managed IP67 Switch 14x10/100 Mbps M12 and 2x100 Mbps Multimode (MicroFX connector)
• OCTOPUS 24M	Managed IP67 Switch 24x10/100 Mbps M12 
• OCTOPUS 24M-Train	Managed IP67 Switch 24x10/100 Mbps M12, EN 50155
• OCTOPUS 24M-2FX	Managed IP67 Switch 22x10/100 Mbps M12 and 2x100 Mbps Multimode (MicroFX connector)
• OCTOPUS 8M-6PoE	Managed IP67 Switch 8x10/100 Mbps M12 with 6 PoE ports 
• OCTOPUS 8M-8PoE	Managed IP67 Switch 16x10/100 Mbps M12 with 8 PoE ports
• OCTOPUS 16M-8PoE	Managed IP67 Switch 24x10/100 Mbps M12 with 8 PoE ports 
• OCTOPUS 16M-8PoE-2FX	Managed IP67 Switch 14x10/100 Mbit/s M12 with 8 PoE + 2 FX ports

OCTOPUS IP67 Switches with Fiber Optic Uplinks FE/GE

• OCTOPUS OS20-0010001M1MTREPHH	Managed IP67 Switch 8xFE M12, 2xFE FO-Multimode V1 
• OCTOPUS OS20-0010001S1STREPHH	Managed IP67 Switch 8xFE M12, 2xFE FO-Singlemode V1
• OCTOPUS OS20-0010004M4MTREPHH	Managed IP67 Switch 8xFE M12, 2xFE FO-Multimode V4
• OCTOPUS OS20-0010004S4STREPHH	Managed IP67 Switch 8xFE M12, 2xFE FO-Singlemode V4
• OCTOPUS OS30-0008021A1ATREPHH	Managed IP67 Switch 8xFE M12, 2xFE FO-Multimode V1
• OCTOPUS OS30-0008021B1BTREPHH	Managed IP67 Switch 8xFE M12, 2xFE FO-Singlemode V1
• OCTOPUS OS30-0008024A4ATREPHH	Managed IP67 Switch 8xFE M12, 2xFE FO-Multimode V4
• OCTOPUS OS30-0008024B4BTREPHH	Managed IP67 Switch 8xFE M12, 2xFE FO-Singlemode V4

Rack Mounted Switches

MACH1000 19" Ruggedized Switches

Going above and beyond the capabilities of the already rugged Hirschmann™ switches, these ruggedized switches are extremely immune to noise and able to provide maximum uptime in extreme environmental conditions.



Fast Ethernet MACH1000

The MACH1000 features a 24-port custom configurable/modular design that is also available with two or four Gigabit uplink ports (RJ45 and/or SFP for fiber). The modular design can meet almost any media-mix need – all copper, all fiber (Multimode and/or Singlemode) or any combination of copper and fiber.

Standard features include:

- 19" rack-mount, fanless design
- -40°C up to +85°C standard operating temperature (conformal coating available)
- Exceeds IEC 61850-3 and IEEE1613 standards for electric power substation communication equipment
- Exceeds NEMA TS-2 standard for traffic control equipment
- Redundant 24/36/48 VDC or 120/250 VDC and 110/230 VAC
- Extremely efficient components for minimal heat generation and high MTBF (Mean Time Between Failure)
- Ultra-fast ring recovery time <10 ms



Gigabit Ethernet MACH1000

The Gigabit Ethernet MACH1000 comes with 16 Gigabit Ethernet Combo ports for highest media flexibility. For building reliable networks, the MACH1000 offers ultra-fast ring recovery time <10 ms, fanless design and a flexible and redundant power input range of 24/36/48 VDC, 125/250 VDC or 110/230 VAC in each possible combination.

Standard features include:

- 19" rack-mount, fanless design
- 16 Gigabit Ethernet Combo ports, optional 4 PoE ports
- Versions available with ports in the front or on the rear
- Fast device replacement via Autoconfiguration adapter (ACA21-USB)
- -40°C up to +70°C operating temperature (conformal coating available)
- Exceeds NEMA TS-2 standard for traffic control equipment, EN50155 and EN50121-4 for rolling stock applications and IEC61850-3 and IEEE1613 standards for electric power substation communication equipment
- Ultra-fast ring recovery time <10ms

Part Number Configurator

Design	Ports GE	Ports FE	Temp. range	Power supply 1	Power supply 2	Ap-provals	Software version	Configu-ration	OEM-Type	Software release
MAR1030-	CC	MM	U	C	C	H	P	H	H	04.0.

Due to the vast number of switch variations (port density, port type, approvals, power input, etc.), Hirschmann™ has developed a part number matrix that permits users to customize their own switch. Simply decide on Compact or Modular, number of ports, the type of uplink ports (these can be used as standard ports), and select the temperature, power and approvals. The configurator can be found at: www.beldensolutions.com/configurator



Rack Mounted Switches



MACH4000 Gigabit Backbone Layer 2/3 Switches

Capable of providing as many as 48 Gigabit ports and three 10 Gigabit ports, the MACH4000 is the ultimate high-density Layer 2/3 Gigabit backbone switch for mission-critical applications requiring high-availability and high port densities.

The MACH4000 comes standard with up to 16+ ports and can then be configured with as many as 32 additional ports (via hot-plug copper/fiber modules).

Standard features include:

- 19" rack-mount
- Two user-definable fault relays
- Hot-swappable media modules for continuous operation – up to 4 Media Modules (8 ports max. each)
- HIPER-Ring, redundant coupling and link aggregation capable
- Flexible power options: 100–240 VAC, 24 VDC and 48 VDC
- 0°C up to +60°C operating temperature

* Fan module is included in each chassis. Please purchase media modules and power supply separately. See accessories on page 53 for SFPs + XFP. Configuration will dictate final port count and media type.

** Media modules sold separately – see next page/software functionality (see page 45)

<ul style="list-style-type: none"> • MACH4002 48+4G-L2P • MACH4002 48+4G-L3E • MACH4002 48+4G-L3P • Fixed ports 	Layer 2, Professional Management chassis Layer 3, Enhanced Management chassis Layer 3, Professional Management chassis 4x Gigabit Ethernet combo ports* (1000 Mbps SFP socket or 10/100/1000 Mbps RJ45) and 16x RJ45 10/100 Mbps
<ul style="list-style-type: none"> • Media modules** 	4 sockets (8 ports max each) for total 32 ports 10/100 Mbps

<ul style="list-style-type: none"> • MACH4002-24G-L2P • MACH4002-24G-L3E • MACH4002-24G-L3P • Fixed ports 	Layer 2, Professional Management chassis Layer 3, Enhanced Management chassis Layer 3, Professional Management chassis 8x Gigabit Ethernet combo ports* (SFP dual speed socket or TP 10/100/1000 Mbps)
<ul style="list-style-type: none"> • Media modules** 	2x sockets (8 ports max each) for total 16 ports 10/100/1000 Mbps

<ul style="list-style-type: none"> • MACH4002-24G+3X-L2P • MACH4002-24G+3X-L3E • MACH4002-24G+3X-L3P • Fixed ports 	Layer 2, Professional Management chassis Layer 3, Enhanced Management chassis Layer 3, Professional Management chassis 3x10 Gigabit Ethernet XFP socket and 8 Gigabit Ethernet ports TP/RJ45 10/100/1000 Mbps
<ul style="list-style-type: none"> • Media modules** 	2x sockets (8 ports max each) for total 16 ports 10/100/1000 Mbps

<ul style="list-style-type: none"> • MACH4002-48G-L2P • MACH4002-48G-L3E • MACH4002-48G-L3P • Fixed ports 	Layer 2, Professional Management chassis Layer 3, Enhanced Management chassis Layer 3, Professional Management chassis 16 Gigabit Ethernet (8 Gigabit Ethernet combo ports* 100/1000 Mbps SFP dual speed socket or 10/100/1000 Mbps + 8 Gigabit 10/100/1000 Mbps RJ45)
<ul style="list-style-type: none"> • Media modules** 	4 sockets (8 ports max each) for total 32 ports 10/100/1000 Mbps

<ul style="list-style-type: none"> • MACH4002-48G+3X-L2P • MACH4002-48G+3X-L3E • MACH4002-48G+3X-L3P • Fixed ports 	Layer 2, Professional Management chassis Layer 3, Enhanced Management chassis Layer 3, Professional Management chassis Three 10 Gigabit Ethernet XFP sockets and 16 Gigabit Ethernet ports (100/1000 Mbps SFP dual speed socket or 10/100/100 Mbps RJ45)
<ul style="list-style-type: none"> • Media modules** 	4 sockets (8 ports max each) for total 32 ports 10/100/100 Mbps

Rack Mounted Switches

MACH4000 Media Modules

These media modules provide maximum flexibility, with 10/100/1000 Mbps over Twisted Pair or 100/1000 Mbps over optical fiber with data transmission ranges of more than 80 km.



MACH4000 Media Modules

- M4-8TP-RJ45 8x10/100/1000 Mbps RJ45 (no 1000 Mbps with MACH4002 48+4G)
- M4-FAST 8-SFP 8x100 Mbps SFP sockets*
- M4-FAST 8TP-RJ45-PoE 8x10/100 Mbps RJ45 ports with Power over Ethernet
- M4-GIGA 8-SFP 8x100/1000 Mbps SFP sockets* (not for MACH4002 48+4G)

* SFPs need to be purchased separately (see accessories page 53 for SFPs)

MACH4000 Internal Power Supplies

- M4-S-AC/DC 300W 110–240 VAC internal power module (redundancy in combination with M4-POWER chassis and power supply)
- M4-S-24VDC 300W 24 VDC internal power module (redundancy power input)
- M4-S-48VDC 300W 48 VDC internal power module (redundancy power input)

MACH4000 External Power Supplies

- M4-POWER Rack-mounted external power chassis. Requires at least one M4-P power supply (more for redundant power) max 3 power supplies
- M4-P AC/DC 300W 110–240 VAC power module for use with external M4-POWER chassis
- M4-P DC 24V 300W 24 VDC power module for use with external M4-POWER chassis (redundant power input)
- M4-P DC 48V 300W 48 VDC power module for use with external M4-POWER chassis (redundant power input)
- M4-POWERCABLE Spare power cable to connect M4-POWER and MACH4002. 1 meter

MACH4000 Accessories

- M4-AIR Fan module (included with chassis), has 4 redundant fans with fault notification
- M4-AIR-L Reduced speed for max 40°C
- M4-RACKMOUNT-50 19" fixing brackets offer 50 mm more space for cables in the front
- M4-RACKMOUNT 19" spare fixing brackets

Fan module is included in each chassis. Please purchase media modules and power supply separately. See accessories on page 53 for SFPs + XFP. Configuration will dictate final port count and media type.

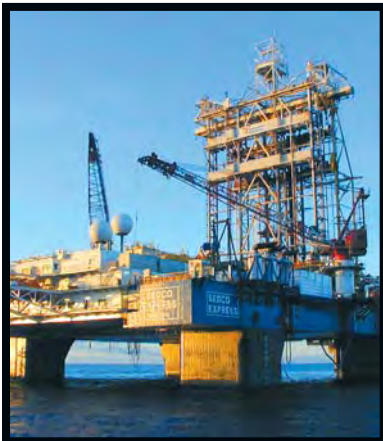



Workgroup Switches

MACH100 Industrial Workgroup Switches

Hirschmann™ has expanded its product range with the Fast and Gigabit Ethernet workgroup switches of the MACH100 family. These switches support PROFINET and EtherNet/IP protocols. This way workgroups can be networked by copper cables and via fiber optics, and can be connected to the backbone. For this purpose the Fast Ethernet MACH100 supports 2 Gigabit Combo ports. The switches are offered in versions with 8 or 24 permanently installed Fast Ethernet ports, or as modular devices with 8 ports and slots for 2 additional 8 port media modules. The new Gigabit Ethernet MACH100 offers 20 GE Twisted Pair ports and 4 GE Combo ports. A version with 4 PoE ports for connecting of IP phones or camera's is also available.

The FE and GE MACH100 switches are designed for a temperature range of 0°C up to +50°C and support a large range of management and redundancy modes, as well as several functions for configuration and diagnostics. Further features are fanless cooling as well as an optional power supply. As a result the devices of the MACH100 family offer a high level of security and flexibility for Ethernet network design or upgrade in production-related areas.

Standard features include:

- Fanless design
- Hot-swappable modules (only FE MACH100)
- ACA 21 USB Backup
- Hirschmann™ CLI and WEB interface
- Range of functions similar to L2P firmware
 - DHCP Option 82, HiDiscovery
 - HIPER-Ring, MRP, RSTP, disable learning, SNTP
 - Industrial Profiles (EtherNet/IP, PROFINET)
- Fully integrated in Industrial HiVision
- Temperature range: 0°C up to +50°C
- Optional 4 PoE ports

Fast Ethernet MACH100	
• MACH102-8TP	8x10/100BASE-TX ports, RJ45 2x GE combo ports (FE or GE SFPs), 2x 8 port media module slot
• MACH102-8TP-R	8x10/100BASE-TX ports, RJ45 2x GE combo ports (FE or GE SFPs), 2x 8 port media module slot, redundant 230 VAC power supply
• MACH102-8TP-F	8x10/100BASE-TX ports, RJ45 2x GE combo ports (FE or GE SFPs)
• MACH102-8TP-FR	8x10/100BASE-TX ports, RJ45 2x GE combo ports (FE or GE SFPs), redundant 230 VAC power supply
• MACH102-24TP-F	24x10/100BASE-TX ports, RJ45 2x GE combo ports (FE or GE SFPs)
• MACH102-24TP-FR	24x10/100BASE-TX ports, RJ45 2x GE combo ports (FE or GE SFPs), redundant 230 VAC power supply
• M1-8TP-RJ45	8x10/100BASE-TX, RJ45 media module
• M1-8MM-SC	8x100BASE-FX MM, SC media module
• M1-8SM-SC	8x100BASE-FX SM, SC media module
• M1-8SFP	8x100BASE-X for SFP media module

Gigabit Ethernet MACH100	
• MACH104-20TX-F	20x10/100/1000BASE-TX, RJ45; 4x GECombo ports (FE or GE SFPs)
• MACH104-20TX-FR	20x10/100/1000BASE-TX, RJ45; 4x GECombo ports (FE or GE SFPs) redundant 230 VAC power supply
• MACH104-20TX-F-4PoE	20x10/100/1000BASE-TX, RJ45; 4x GECombo ports (FE or GE SFPs) 4x GE PoE ports with integrated PoE power supply (up to 15,4 watts per port)



PowerLION

As Hirschmann™ provides true “boardroom to factory floor” networking, the product range includes high quality, high performance switches without industrial ratings. The PowerLION meets the needs of IT professionals. The full-featured management and high traffic performance makes the PowerLION compatible with larger office-grade brands while maintaining cost effectiveness.



PowerLION Modules

- PowerLION-24TP Stacking cable, 30 cm
- PowerLION-24TP Stacking cable, 130 cm
- PowerLION-24TP 10 Gigabit uplink module – requires XENPAK-10G-LR below
- XENPAK-10G-LR 10 Gigabit Ethernet transceiver for PowerLION 10GE uplink module

PowerLION

- PowerLION-24TP Layer-3, 24 x 10/100/1000 BASE-T ports RJ45, 4 of which are Gigabit STP combo port





Software Functionality

L2 Basic	L2 Enhanced	L2 Professional	L3 Enhanced	L3 Professional		
		●	●	●	DHCP server per port	Plug & Work
		●	●	●	IP address conflict detection	
		●	●	●	Multiple stored firmware versions	
	●	●	●	●	Automatic configuration undo	
●	●	●	●	●	DHCP relay agent, option 82	
●	●	●	●	●	External flash memory	
		●	●	●	IEEE 802.1x	Security
		●	●	●	SSH	
		●	●	●	SNMP v2c, v3 encryption	
		●	●	●	Port security IP, multiple addresses	
	●	●	●	●	Port security MAC	
	●	●	●	●	Port security IP	
●	●	●	●	●	SNMP v2c, v3 (password encryption)	
		●	●	●	GVRP	Switching
		●	●	●	Multicast GMRP – 802.1D	
		●	●	●	Optimized for video multicasting	
	●	●	●	●	Static VLAN, Q-MIB – 802.3ac, 802.1Q	
	●	●	●	●	Broadcast, unicast, multicast limiter	
	●	●	●	●	Multicast IGMP querier	
●	●	●	●	●	Multicast IGMP snooping	
●	●	●	●	●	Port priority – 802.1D/p	
		●	●	●	Link aggregation – 802.3ad	Redundancy
	●	●	●	●	RSTP – 802.1w	
	●	●	●	●	Redundant network coupling	
	●	●	●	●	HIPER-Ring redundancy manager	
●	●	●	●	●	HIPER-Ring	
●	●	●	●	●	MRP-Ring	
	●	●	●	●	PROFINET Profile	Pro-files
	●	●	●	●	EtherNet/IP Profile	
				●	DVMRP/PIM DM multicast routing	Routing
				●	OSPF	
			●	●	RIP v1/v2	
			●	●	Static routing	
			●	●	VRRP, HiVRRP (< 500 ms) router redundancy	
			●	●	Layer 3 ACL	
		●	●	●	Text configuration file	Diagnostic
		●	●	●	Cable diagnostic TX	
		●	●	●	Automatic configuration check	
	●	●	●	●	HuB functionality (disable learning)	
	●	●	●	●	Syslog	
●	●	●	●	●	Log file	
●	●	●	●	●	Port mirroring	
●	●	●	●	●	Topology discovery 802.1ab	

Enjoy the benefits of direct, hassle-free configuration with our online tool at: www.beldensolutions.com/configurator

Switch and Network Management



Industrial Profiles

Switch management within EtherNet/IP and PROFINET

Available for OpenRail, MACH and OCTOPUS, Hirschmann™'s Industrial Profiles are a valuable addition to the managed switches' firmware.

The functionality provides an almost seamless integration between Hirschmann™'s managed switches and either EtherNet/IP (Allen-Bradley) or PROFINET (Siemens) platforms. Using this functionality, all switch data will be readily accessible to the PLC/HMI for easier network management, security and safety. The industrial profiles also permit PLC/HMI access to switch status, port link status, IGMP settings, network statistics – even the automatic enabling and disabling of individual ports.

OpenRail users with firmware prior to 3.0 can upgrade simply by downloading and flashing the updated firmware onto the switch.

Field Device Tool

Field Device Tool (FDT)/Device Type Management (DTM)

Hirschmann™ is now the first manufacturer to introduce Device Type Management (DTM) for Industrial Ethernet. This tool enables the integration of switches and other infrastructure components into FDT systems to perform detection, configuration or diagnostics along with other field devices, e.g. actuators and sensors.

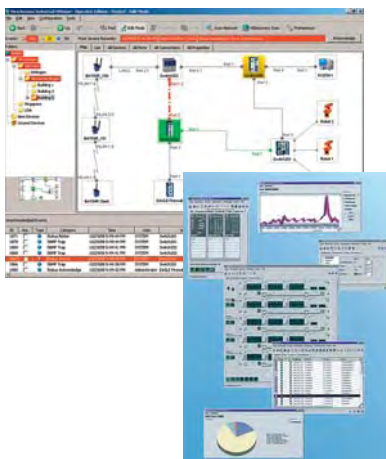

HiVision

HiVision Network Management Software

Ideally suited for the commissioning and maintenance of larger networks, HiVision permits users to have realtime control and feedback with/from multiple switches. Faults and network status information are readily viewed on the application's GUI, permitting users to make knowledgeable decisions and troubleshoot issues. Provides network statistics, including bandwidth utilization.

Compatible with managed OpenRail, PowerMICE, MACH, BAT and OCTOPUS switches. HPUX versions available upon request.

HiVision

- HiVision PC-Based Enterprise (for office-grade switches), full version
- HiVision PC-Based Industrial (for industrial switches), full version
- HiVision PC-Based Enterprise Update (for office-grade switches), upgrade version
- HiVision PC-Based Industrial (for industrial switches), upgrade version



Industrial HiVision Network Visualization Software

Ideally suited for auditing and monitoring network connections and throughputs, Industrial HiVision permits users to have realtime feedback from multiple switches regarding the network and link status. The application's GUI illustrates the network as it is, while providing network statistics (incl. bandwidth utilization) and live/lost links.

Industrial HiVision includes an OPC server. The GUI is also available as an ActiveX control, for integration into SCADA applications.

Industrial HiVision

- Industrial HiVision, to view up to 25 nodes
- Industrial HiVision, to view up to 50 nodes
- Industrial HiVision, to view up to 100 nodes
- Industrial HiVision, to view up to 250 nodes
- Industrial HiVision, to view up to 500 nodes

* Full version required

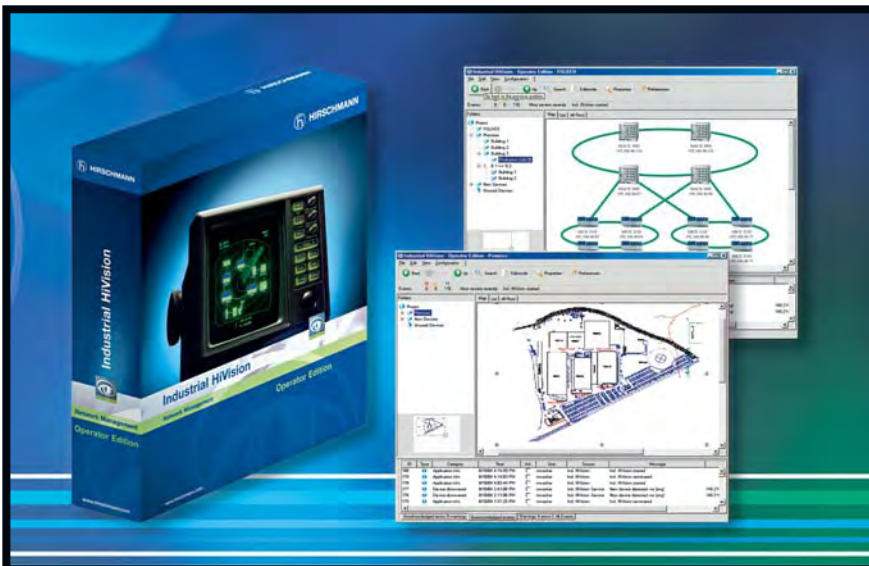

BAT Wireless Access Points, Clients and Bridges



BAT Family

Hirschmann™ provides industrial grade WLAN hardware with cutting-edge technology. Hirschmann™ BAT300 are the first industrial access points offering "line speed Ethernet over the air".

Standard features include:

- Rugged housing for installation on DIN rails, walls or poles, IP40 or IP65/67 ingress protection
- Extended temperature range: -30°C to at least +50°C
- Up to 2 built-in wireless interfaces which support all WLAN standards
- Multiple 24 VDC power redundancy (up to 5x), Power over Ethernet (802.3af) and 12 V
- IEEE802.11i with PSK, LEPS, 802.1x and RADIUS for maximum WLAN security

The BAT family products are ideally suited for:

- Harsh conditions in- and outdoor industrial applications where the units are exposed to moisture, cold or extreme heat
- Applications where high operational reliability and redundancy are essential
- Installations where the devices must meet very stringent EMC and noise immunity requirements
- High-security networks that offer segmentation and authentication in addition to basic WLAN functionality

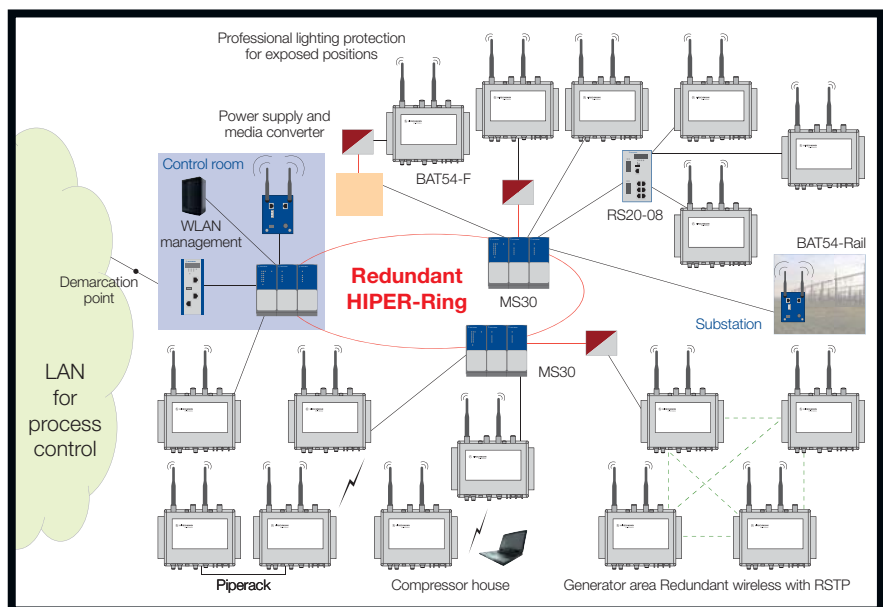



BAT-F

The devices are supplied in IP65/67 metal housings. They are designed for field-level applications or harsh industrial environments.

BAT54	
• BAT54-F	Dualband Ruggedized Industrial Wireless LAN Access Point/Client with two independent radio modules with IEEE 802.11a/b/g/h/i for installation in harsh environment
• BAT54-F FCC	Dualband Ruggedized Industrial Wireless LAN Access Point/Client with two independent radio modules with IEEE 802.11a/b/g/h/i for installation in harsh environment, with FCC-approval for USA and Canada.
• BAT54-F X2	Dualband Ruggedized Industrial Wireless LAN Access Point/Client with two independent radio modules with IEEE 802.11a/b/g/h/i for installation in hazardous environment
• BAT54-F X2 FCC	Dualband Ruggedized Industrial Wireless LAN Access Point/Client with two independent radio modules with IEEE 802.11a/b/g/h/i for installation in hazardous environment, with FCC-approval for USA and Canada.
• BAT54-F Single	Dualband Ruggedized Industrial Wireless LAN Access Point/Client with one radio module with IEEE 802.11a/b/g/h/i and two PoE/LAN ports for installation in harsh environment
• BAT54-F Single FCC	Dualband Ruggedized Industrial Wireless LAN Access Point/Client with one radio module with IEEE 802.11a/b/g/h/i for installation in harsh environment, with FCC-approval for USA and Canada
• BAT54-F Client	Dualband Ruggedized Industrial Wireless LAN Client with one radio module with IEEE 802.11a/b/g/h/i for installation in harsh environment
• BAT54-F Client FCC	Dualband Ruggedized Industrial Wireless LAN Client with one radio module with IEEE 802.11a/b/g/h/i for installation in harsh environment, with FCC-approval for USA and Canada

BAT300	
• BAT300-F	Dualband Ruggedized Industrial Wireless LAN Access Point/Client with two independent radio modules with IEEE 802.11n for installation in harsh environment
• BAT300-F FCC	Dualband Industrial high performance Wireless LAN Access Point/Client IEEE 802.11n, with FCC-approval for USA and Canada

Accessories

• BAT-ANT-Protector m-f	Overvoltage protector for antennas N jack to N plug; frequency range 2 GHz–6 GHz, attenuation = <0.2 dB
• BAT-CLB-15 N m-f	Antenna cable, 15 m, N-connector to N-socket
• BAT-CLB-2 N m-f	Antenna cable, 2 m, N-plug to N-jack, 2.4 GHz to 6 GHz
• BAT-LAN-Protector IP68	Overvoltage protector for LAN cable, IP68 sealed housing, RJ45 plugs
• BAT-Pigtail	Adapter cable (N female/RP-SMA-Plug)
• BAT54-F, Pole mounting set	Adapter for pole mounting

BAT-Rail

The devices are supplied in a metal enclosure for mounting on DIN rails in automation or vehicle applications.

BAT54	
• BAT54-Rail	Dualband Industrial Wireless LAN Access Point/Client with two independent radio modules with IEEE 802.11a/b/g/h/i
• BAT54-Rail - FCC	Dualband Industrial Wireless LAN Access Point/Client with two independent radio modules with IEEE IEEE 802.11a/b/g/h/i. With FCC-approval for USA and Canada.
• BAT54-Rail - Japan	Dualband Industrial Wireless LAN Access Point/Client with two independent radio modules with IEEE 802.11a/b/g/h/i. Approved for operation in Japan.
• BAT54-Rail Client	Dualband industrial Wireless LAN Client with one radio module with IEEE 802.11a/b/g/h/i
• BAT54-Rail Client - FCC	Dualband industrial Wireless LAN Client with two independent radio modules with IEEE 802.11a/b/g/h/i. With FCC-approval for USA and Canada.

BAT300	
• BAT300-Rail	Dualband Industrial high performance Wireless LAN Access Point/Client with 802.11n
• BAT300-Rail FCC	Dualband Industrial high performance Wireless LAN Access Point/Client IEEE 802.11n

Antennas

• BAT-ANT-N-14G-IP65	2400 MHz–2500 MHz
• BAT-ANT-N-18A-V-IP65	Directional antenna for 5GHz band
• BAT-ANT-N-23A-VH-IP65	Narrow beam directional antenna for usage with 802.11n
• BAT-ANT-N-23A-V-IP65	Directional high gain antenna, 23 dBi for 5 GHz band
• BAT-ANT-N-5A-IP65	Omnidirectional antenna for 5 GHz band
• BAT-ANT-N-6ABG-IP65	Hemispherical antenna for 2.4 and 5 GHz band
• BAT-ANT-N-6G-IP65	Omnidirectional antenna for 2.4 GHz band
• BAT-ANT-N-8G-DS-IP65	2,4 GHz with dual slant also suited for operation with 802.11n
• BAT-ANT-N-9A-DS-IP65	5GHz with dual slant also suited for operation with 802.11n
• BAT-ANT-N-MiMoDB-5N-IP65	Dualband omnidirectional for 802.11n
• BAT-ANT-N-MiMo5-9N-IP65	5 GHz sector for 802.11n

BAT-ANT antennas are high quality accessories supporting the cutting-edge features of BAT devices. The brand new MiMo antennas offer full support of 802.11n "Ethernet-over-the-Air" throughput. With BAT accessories and antennas, all components for a complete WLAN installation are available. All antennas are equipped with required adapters and cables for seamless use with the BAT Access Points.

Security



EAGLE20 Firewall/VPN Router

A high speed VPN, firewall, and routing solution all in one package, the EAGLE20 allows users to achieve the highest level of security for Industrial Ethernet networks. All security functions are integrated into the self-contained independent EAGLE20 platform, eliminating the need to reconfigure the system being protected or install additional drivers or software. The EAGLE20 is configured via an intuitive web interface, including VPN wizard. A comprehensive Command Line Interface is available, allowing complete control via scripting.

- Scalable security functionality: pure firewall, and VPN router
- Easy integration: no need to change IP addresses in existing networks
- Simple deployment: visible in HiDiscovery, and support for the USB auto configuration adapter
- Extensive diagnostics: web-based management, status LEDs, relay contact, logging to a Syslog server, integrated in HiVision
- Support for redundancy mechanisms: firewall redundancy, redundant ring coupling, network segmentation (router mode), fanless design

Trusted Port		Untrusted/Public Port	
• EAGLE20 TX/TX	10/100BASE-TX, RJ45	• EAGLE20 TX/TX	10/100BASE-TX, RJ45
• EAGLE20 TX/MM	10/100BASE-TX, RJ45	• EAGLE20 TX/MM	100BASE-FX-MM, SC
• EAGLE20 TX/SM	10/100BASE-TX, RJ45	• EAGLE20 TX/SM	100BASE-FX-MM, SC
• EAGLE20 MM/TX	100BASE-FX-MM, SC	• EAGLE20 MM/TX	10/100BASE-TX, RJ45
• EAGLE20 MM/MM	100BASE-FX-MM, SC	• EAGLE20 MM/MM	100BASE-FX-MM, SC

Further Interfaces

- Supply fault relay output: 1x pluggable terminal block, 6 pin
- V.24 port: 1x RJ11 socket, serial interface for device configuration
- USB interface: 1x USB for connection to ACA 21-USB

Security

- Stateful Inspection Firewall: Firewall rules (incoming/outgoing, modem access, management), IP Masquerading, 1-to-1 NAT, DoS Limiter, MAC Filter, user firewall for ext. activation of FW-rules
- Multipoint VPN: IPSec, IKEv2, DES, 3DES, AES (-128, -192, -256), Pre-Shared Key, X.509v3 Certificate, MD5, SHA-1, NAT-T, firewall rules for each VPN connection, configuration assistance via web interface, remote-controlled activate/deactivate connection

Service

- Management: Command Line Interface (CLI), web interface, auto configuration adapter (ACA 21-USB), DHCP, HiDiscovery, Industrial HiVision
- Diagnostics: LEDs (power, link status, data, fault, ACA (V24), relay contact (24 VDC/1A), Log file, Syslog
- Protocols: Serial, HTTPS, SSH, SNMP v1/v2/v3), LLDP
- Further features: DHCP server/client, DHCP relay/option 82, DynDNS, firewall-access via V.24 (PPP), SNMP, VLAN support (IEEE 802.1pQ), port-forwarding

Redundancy

- Redundancy functions: Use in redundant network-/ ring coupling, firewall redundancy (layer 4), redundant 24 V power supply





Transceivers and FiberINTERFACES

Rail Transceivers and Hubs

Hirschmann™'s Rail Transceivers convert between RJ45 and fiber ports. For applications that require additional RJ45 ports (as shown below), we would like to recommend using a switch with a fiber optic port(s).



FiberINTERFACES/Universal Fiber Optic Transceivers

For the most commonly used Fieldbus protocols, Hirschmann™ has developed a series of copper-fiber converters (also often referred to as fiber repeaters), permitting users to extend the range of their Fieldbus signals beyond the limitations of copper. The fiber optic repeaters are used in mission-critical applications where electromagnetic influences may be present. Because of fiber's properties, RFI/EMI has no influence on the reliability of the fiber optic links.

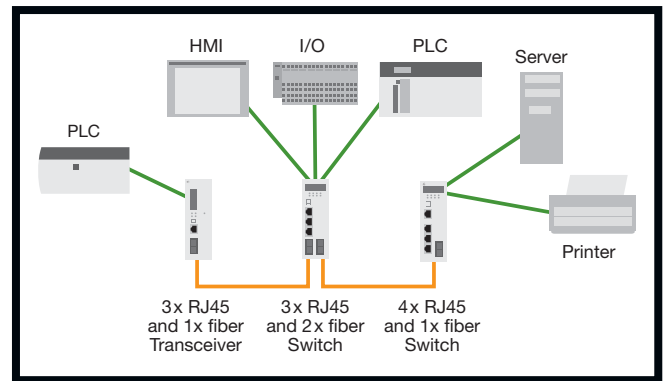

SPIDER 1/TX/1FX SPIDER 1/TX/1FX EEC SPIDER 1/TX/1FX-SM SPIDER 1/TX/1FX-SM EEC

- 1x10/100Base-TX, RJ45
- 1x100Base-FX, MM or SM, SC sockets
- 1 pluggable terminal block, 24 VDC



RS232 Media Converters

- OZDV 2451P 1 electrical, 1 optical portbus-powered, POF 0–60 m
- OZDV 2451G 1 electrical, 1 optical portbus-powered, Multimode 0–2000 m
- OZDV 2471P 1 electrical, 1 optical port, POF 0–100 m, HCS 0–2100 m
- OZDV 2471G 1 electrical, 1 optical port, Multimode 0–6700 m
- OZDV 2471G-1300 1 electrical, 1 optical port, Singlemode 0–32 km



RT2-TX/FX

- 1x10/100Base-TX, RJ45
- 1x100Base-FX, MM, SC sockets
- 1 pluggable terminal block, redundant 24 VDC inputs, link loss alarm, power loss alarm, fault relay output



RS485 Repeater

- OZD 485 G12 BASIC 1 electrical, 2 optical ports, Multimode – line capable
- OZD 485 G12 PRO 1 electrical, 2 optical ports, predictive maintenance Multimode – redundant ring capable
- OZD 485 G12-1300 PRO 1 electrical, 2 optical ports, predictive maintenance Singlemode – redundant ring capable



The fiber optic connections offer capabilities well beyond the 100 m limitation of Twisted Pair (TP) cabling (in green) – up to 80 km without the use of repeaters (using long haul singlemode). Additionally, fiber optics offer RFI/EMI noise immunity, making it ideal for outdoor cabling requirements.

FiberINTERFACES/Fieldbus Repeaters

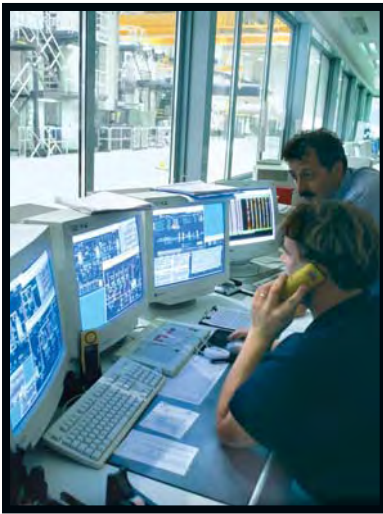

Profibus Plug-on Repeaters

- OZD ProfiPlug P11 1 electrical, 1 optical port, bus-powered, POF 0–75 m, HCS 0–100 m
- OZD ProfiPlug P21 2 electrical, 1 optical port, bus-powered, POF 0–75 m, HCS 0–100 m



Profibus Repeaters

- OZD PROFIBUS 12M P11 For plastic fiber, 1 electrical, 1 optical port
- OZD PROFIBUS 12M P12 For plastic fiber, 1 electrical, 2 optical ports redundant ring capable
- OZD PROFIBUS 12M G11 1 electrical, 1 optical port, multimode
- OZD PROFIBUS 12M G12 1 electrical, 2 optical ports, multimode – redundant ring capable
- OZD PROFIBUS 12M G12 EEC 1 electrical, 2 optical ports, multimode – redundant ring capable, EEC*
- OZD PROFIBUS 12M G11 1300 1 electrical, 1 optical port, singlemode
- OZD PROFIBUS 12M G12 1300 1 electrical, 2 optical ports, singlemode – redundant ring capable
- OZD PROFIBUS 12M G12 1300 EEC 1 electrical, 2 optical ports, singlemode – redundant ring capable, EEC*



- OZD PROFIBUS 12M P11 PRO 1 electrical, 1 optical port, predictive maintenance, POF
- OZD PROFIBUS 12M P12 PRO 1 electrical, 2 optical ports, predictive maintenance, POF, redundant ring capable
- OZD PROFIBUS 12M G11 PRO 1 electrical, 1 optical port, predictive maintenance, multimode
- OZD PROFIBUS 12M G12 PRO 1 electrical, 2 optical ports, predictive maintenance, multimode, redundant ring capable
- OZD PROFIBUS 12M G12 EEC PRO 1 electrical, 2 optical ports, predictive maintenance, multimode, redundant ring capable, EEC*
- OZD PROFIBUS 12M G11-1300 PRO 1 electrical, 1 optical port, predictive maintenance, singlemode
- OZD PROFIBUS 12M G12-1300 PRO 1 electrical, 2 optical ports, predictive maintenance, singlemode, redundant ring capable
- OZD PROFIBUS 12M G12-1300 PRO 1 electrical, 2 optical ports, predictive maintenance, singlemode, redundant ring capable, EEC*



* Devices showing EEC can operate in extended environmental conditions: -20°C up to +60°C, 100% humidity

Profibus ATEX Zone 1 Repeaters

- OZD PROFIBUS G12DU ATEX 1 1 electrical, 2 optical ports, predictive maintenance, multimode, redundant ring capable, cabinet assembly
- OZD PROFIBUS G12DK ATEX 1 1 electrical, 2 optical ports, predictive maintenance, multimode, redundant ring capable, plastic IP67 housing for mounting in ATEX-certified housing
- OZD PROFIBUS G12DE ATEX 1 1 electrical, 2 optical ports, predictive maintenance, multimode, redundant ring capable, stainless steel IP67 housing



Geniusbus Repeaters

- OZD GENIUS G12 1 electrical, 2 optical ports, redundant ring capable
- OZD GENIUS G12 1300 1 electrical, 2 optical ports, singlemode, redundant ring capable



Modbus + Repeaters

- MODBUS PLUS G12 1 electrical, 2 optical ports, redundant ring capable
- MODBUS PLUS G12 1300 1 electrical, 2 optical ports, singlemode, redundant ring capable



WorldFIP Repeaters

- OZD FIP G3 1 electrical, 2 optical ports, multimode, redundant ring capable
- OZD FIP G3 T 1 electrical, 2 optical ports, multimode, redundant ring capable, bus-termination included





Accessories

SFP + XFD Modules

Fast Ethernet	
• M-FAST SFP-MM/LC	100BASE-FX, 5 km 50/125 µm MM, 4 km 62.5/12.5 µm MM
• M-FAST SFP-MM/LC EEC	100BASE-FX, 5 km 50/125 µm MM, 4 km 62.5/12.5 µm MM
• M-FAST SFP-SM/LC	100BASE-FX, 25 km 9/125 µm SM
• M-FAST SFP-SM/LC EEC	100BASE-FX, 25 km 9/125 µm SM
• M-FAST SFP-SM+/LC	100BASE-FX, 25–65 km 9/125 µm SM
• M-FAST SFP-SM+/LC EEC	100BASE-FX, 25–65 km 9/125 µm SM
• M-FAST SFP-LH/LC	100BASE-FX, 55–140 km 9/125 µm SM
• M-FAST SFP-LH/LC EEC	100BASE-FX, 55–140 km 9/125 µm SM



Gigabit Ethernet	
• M-SFP-SX/LC	1000Base-SX, 550 m 50/125 µm MM, 275 m 62.5/125 µm MM
• M-SFP-SX/LC EEC	1000Base-SX, 550 m 50/125 µm MM, 275 m 62.5/125 µm MM
• M-SFP-LX/LC	1000Base-SX, 550 m 50/125 µm MM, 550 m 62.5/125 µm MM, 20 km 9/125 µm SM
• M-SFP-LX/LC EEC	1000Base-SX, 550 m 50/125 µm MM, 550 m 62.5/125 µm MM, 20 km 9/125 µm SM
• M-SFP-LH/LC	1000Base-LX, 16–80 km 9/125 µm SM-LH
• M-SFP-LH+/LC	1000Base-LX, 44–120 km 9/125 µm SM-LH



Gigabit Ethernet Bi-Directional	
• M-SFP-BIDI-Bundle LX/LC EEC	1000Base-SX, 20 km 9/125 µm SM
• M-SFP-BIDI-Bundle LH/LC EEC	1000Base-LX, 23–80 km 9/125 µm SM-LH



10 Gigabit Ethernet	
• M-XFP-ZR/LC	10GBASE-SX, 40–80 km 9/125 µm SM
• M-XFP-ER/LC	10GBASE-SX, 10–40 km 9/125 µm SM
• M-XFP-LR/LC	10GBASE-SX, 2–10 km 9/125 µm SM
• M-XFP-SR/LC	10GBASE-SX, 33 m 50/125 µm MM or 300 m w/modal bandwidth 2000 [MHz x km] fiber



Power Supplies	
• RPS30	24 VDC power supply unit 1.3A
• RPS80 EEC	24 VDC power supply unit 3.0A, -25°C up to +70°C
• RPS120 EEC	24 VDC power supply unit 4.5A, -25°C up to +70°C
• RPS60/48V EEC	48 VDC PoE power supply unit 1.25A, -10°C up to +70°C
• PSW 5-24	5 VDC Plug-in power supply 0°C up to +40°C



Programming and Configuration Backup	
• ACA 21-USB EEC	The ACA for managed products OpenRail, MICE, MACH, OCTOPUS and EAGLE enables easy commission and quick replacement
• ACA21-M12 EEC	The ACA for managed OCTOPUS Switches enables easy commissioning and rapid replacement
• ACA11 EEC	The ACA saves configuration data via the RS232 interface
• Serial/Terminal Cable	Terminal cable for configuring managed switches via the RS232 interface
• 19" DIN Rail Adapter	Installation rack for 19" cabinet, 8 units wide and 4 units high



Belden offers a range of high quality and state-of-the-art connectivity products from the well-established brands of Lumberg Automation™ and Hirschmann™.

Lumberg Automation™ and Hirschmann™ – For Sophisticated and Superior Industrial Connectivity Solutions

Belden® offers a range of industrial connectivity products, combining the product lines of the Lumberg Automation™ and Hirschmann™ brands. Both Lumberg Automation™ and Hirschmann™ Connectors have a well-established reputation for quality and are used extensively in industrial automation. One of their key characteristics is the robustness of these products, which makes it possible to use these products directly in the field, even under rough environmental conditions.

Belden offers industrial connectivity with a wide range of intelligent wiring solutions, including Fieldbus components, distribution boxes, cord sets and connectors for all industrial applications.

Our products are designed to meet practical needs. Applied a million times over, they stand out through their high mechanical and electrical loading capacity, chemical resistance as well as compact design. From single and double-ended cord sets to centralized or decentralized Fieldbus components, we can offer our customers optimal wiring solutions, whatever application they have in mind.

Lumberg Automation™ and Hirschmann™ expertise and experience form the basis for countless technological innovations. Belden highly developed manufacturing processes enable us to deliver continuously updated, state-of-the-art equipment.

Table of Content	Page
Fieldbus-Systems Local	55–56
LioN Series	55
LioN-Link Series	56
Fieldbus-Systems Central	57
e2c Series	57
Actuator Sensor Boxes	58
ASB Series	58
Cable & Connect Products	59–62
GDM Series	59
CA/CM Series	61
NR Series	61
G Series	61
ST Series	62
Photovoltaic Connectors	63
SunCon Series	63



Fieldbus-Systems Local

LioN Series

In order to ensure high availability of machines and plants, the I/O modules installed in harsh industrial environments must be able to meet the highest electro-mechanical demands. Due to the material of the housing and the casting techniques, the LioN modules provides absolute protection for the electronics. The LioN Classic modules are available with M23 connection technology for hybrid cables (power supply and bus line in a single cable) or with M12 plug connectors for a separate voltage supply.

Because of their compact construction, the LioN-S modules with M8 connections are optimally suitable for plants where space is limited. In addition to the small dimensions, the modules of this series can be fixed at the front, at the side and directly on profile rails.

The different configurations can be realized using a universal module for both the LioN-S and the LioN-M. In these convenient I/O modules, each signal pin can be used either as an input or as an output. This means a very high degree of flexibility in planning for alterations during start-up and for later retrofit. Furthermore, these I/O modules simplify the carrying of spares, which is a time and money saver in the long run.

Key features include:

LioN Classic:

- High degree of reliability in rough environmental conditions – in use for more than 10 years

LioN-M and -S:

- Simple planning and more economical spare parts storage due to universal I/O functionality
- Small connection space thanks to variable installation possibilities
- Low weight – ideally suited for installation and handling applications
- Fast start-up due to comprehensive diagnostics

Technical data:

- Ambient temperature from $-10^{\circ}\text{C}/+60^{\circ}\text{C}$
- Materials (depending on type of module)
 - Housing: PBT or PUR
 - Inserts: PA
 - Contacts: CuZn, pre-nickeled and 0.8 microns gold plated
- Mechanical data
 - Protection class: IP67
- Electrical data
 - Nominal current at 40°C : 0.5 A to 2 A per channel and up to 15 A per module
 - Nominal voltage: 19-30 VDC
- Module variants
 - 8 and 16-way digital universal module with inputs and outputs
 - 8 and 16-way digital input modules

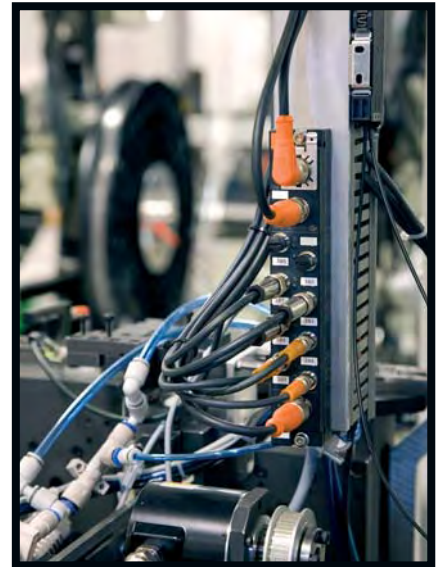



LioN-Link Series

LioN-Link is of interest in cases where the machines or plants have distributed I/O concentrations in limited space conditions. LioN-Link consists of bus couplers and I/O modules. The bus couplers are used for linking the I/O modules to the Fieldbuses. Starting from the bus coupler, the I/O modules divide up decentrally in the field via two strands. In total up to 15 users can be connected to each strand. The overall extension of a strand can extend to 100 m.

Key features include:

- Bus-independent I/O modules ensure a high degree of flexibility and reduce storage requirements
- Space-saving, light-weight modules ensure a wide area of applications
- Simplified planning due to universal I/O modules
- Economical solution – up to 480 I/Os at a single bus coupler
- Quick availability with the use of standardized wiring components

- Easy and safe installation thanks to color-coded sockets
- High degree of reliability as there are no line terminators
- Easy start-up and extension of the plant, because the modules will be operating without manual addressing

Technical data:

- Ambient temperature from -10°C/+60°C
- Materials (depending on type of module)
 - Housing: PBT
 - Inserts: PA
 - Contacts: CuZn, pre-nickel sub-surface and 0.8 micron gold plated
- Mechanical data
 - Protection class: IP67
- Electrical data
 - Nominal current at 40°C: 0.5 A to 2 A per channel and up to 9 A per module
 - Nominal voltage: 19-30 VDC
- Slot types:
 - M8
 - M12
 - Multi-pole interface
- Module variants
 - 8 and 16-way digital universal module with inputs and outputs
 - 8 and 16-way digital input module
 - 4-way analog input module 0-10 V
 - 4-way analog input module 0-20 mA
 - 4-way IO-Link-Master
 - 8-way-Input/4-way Output Motion Module

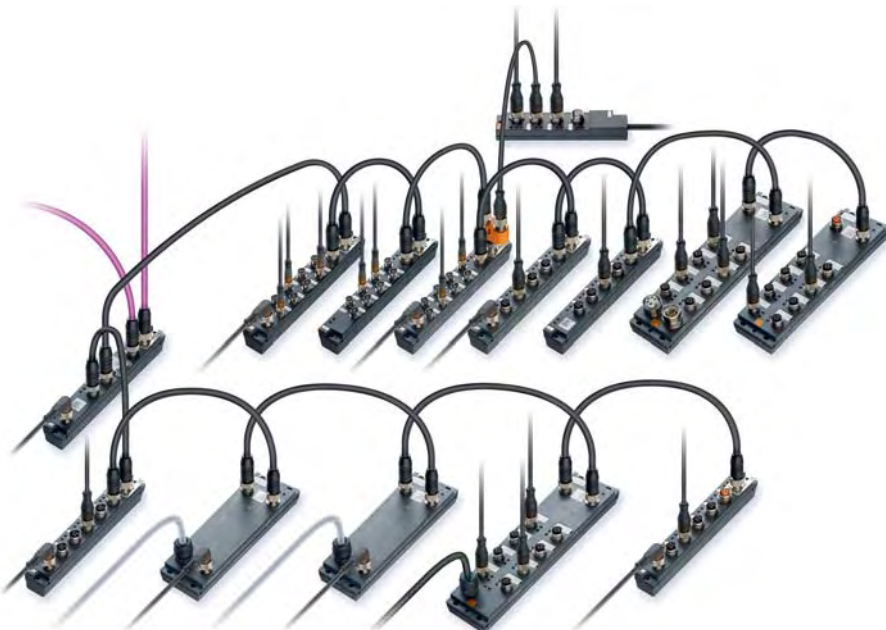



Fieldbus-Systems Central

e2c Series

The modular IP67 distribution system e2c (Easy To Connect) is suitable for decentralized applications in rough industrial environments. The system supports the Profibus DP, DeviceNet and Interbus Fieldbuses and is easy to install and configure. The Fieldbus is determined only by the bus head and the plug box – all other components are bus-independent. With e2c, the user determines which I/O modules are combined with which Fieldbus.

Key features include:

- Bus-independent, compact and high IP rating
- Peripherals can be checked without a bus connection
- Up to 128 signals in the smallest space
- Large bandwidth of I/O modules
- Interface module for linkage to valve terminals and passive distributors
- Plug & Play startup
- Secure contacting due to backplane concept
- Cost-saving due to integration of passive components from the Lumberg product family

Technical data:

- Backplane: for 4, 6 or 8 I/O modules
- Plug boxes:

Product	Bus & Power 2x M12 & 7/8"	Bus & Power 2x M12 & M23	Bus & Power 2x M23 & M23
Profibus	•	•	•
Interbus			•
DeviceNet	•		•

- Bus heads: Profibus, Interbus, DeviceNet
- I/O modules:
 - Digital input (p- or n switched, counter)
 - Digital output (0.5–2 A), also with ext. supply, electrically insulated
 - Multi-pole interface (with dig. input and output channels) for ASB(M) distributor or valve terminals
 - Analog input (+/-10 V, +/-20 mA, 4–20 mA)

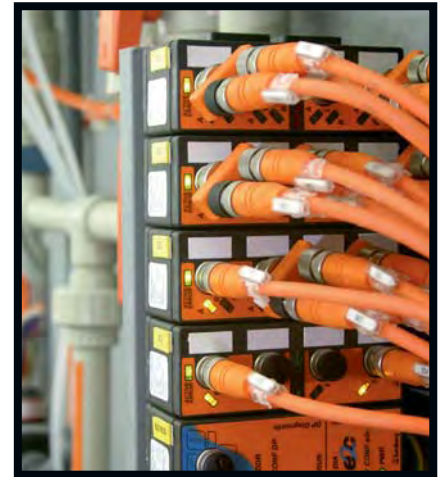

Actuator Sensor Boxes



ASB Series

Whether 4, 6 or 8-way design, single or duplex assignment, with M8 or M12 connections, with fixed cables or as a pluggable variant, with or without LED function indicator – this distributor program leaves hardly any wishes unfulfilled. For particularly rough environments, it offers especially robust distributors with stainless steel housing and stainless steel screwing.

In order to meet the special requirements of the food & beverage industry, the product offer includes distributors whose materials are distinguished by a high degree of resistance to aggressive cleaners and chemicals.

Key features include:

- Space-saving design for multiple applications in a small space
- Quick installation due to several fixing possibilities
- Easy installation thanks to displaced arrangement of the connections in the M8 distributors
- Broad range of applications due to high vibration and shock resistance

Technical data:

- Ambient temperature: -25°C/+80°C
- Materials (depending on type of module)
 - Housing: PBT, TPU or stainless steel
 - Insert: PA or PVC
 - Contacts: CuZn, pre-nickel and 0.8 microns gold plated
- Mechanical data
 - Protection class: IP67/IP69K
- Electrical data
 - Nominal current at 40°C: 1.5 A to 4 A per port and up to 12 A per module
 - Nominal voltage: 10-30 VDC
- Module construction / granularity
 - M8 pluggable: 4-, 6-, 8-, 10-way
 - M8 with cable: 4-, 6-, 8-, 10-, 12-way
 - M12: 4-, 6-, 10-way distributor
 - Single or duplex channel model
 - With/without LED
 - Pluggable or with molded cable





Connect & Cable Products

The sensor connectors and cables are distinguished by the multitude of available standard and special types and are optimally suited for use in many areas of automation and other technologies. The portfolio comprises plug connectors in the model types M5, M8, M12, M23 and 7/8". In addition, the program includes 2-way distributors for I/O modules and T-distributors for the bus connection and the voltage supply of the ProfiBus, DeviceNet and InterBus Fieldbus systems.

Key features include:

- Available with 2 to 19 pins
- Straight and angled variants
- For voltages up to 250 V (M12, M23, 7/8") or 60 V (M5, M8) and currents up to 12 A (7/8"), 10 A (M23), 4 A (M8, M12) or 1 A (M5)
- Available as field-attachable connectors or with molded cables as well as T-distributors
- Cable variants in many lengths with and without LED function indicator
- Numerous connection possibilities – screwed clamp terminals, cage clamp terminals and quick connection technologies
- Compact method of construction with rounded edges and new type of cable path
- Protection class up to IP68/69K



GDM Series

Rectangular connectors of the GDM series for hydraulic, pneumatic and electro-magnetic actuators as well as sensors fulfill the demands of hard practical daily work in every form (Types A/B/C).

Key features include:

- Available as 3 and 4-pin variants (incl. PE)
- For voltages up to 400 V (Type A), 250 V (Types B, C) and currents up to 16 A (Types A, B)/6 A (Type C)
- Available as field-attachable version or with molded cables as well as adapters
- Easy assembly thanks to large cable connection space
- Uncompromising safety: International approvals VDE, UL, CSA, GL
- Further areas of application with forms of Type A (DIN model EN 175301-803) as well as Type B and C (DIN version EN 175301-803 and industrial version)
- Numerous connection possibilities due to patent-protected combination terminal for connecting stranded wires, fork-type eyelets or cable lugs
- Protection class up to IP68



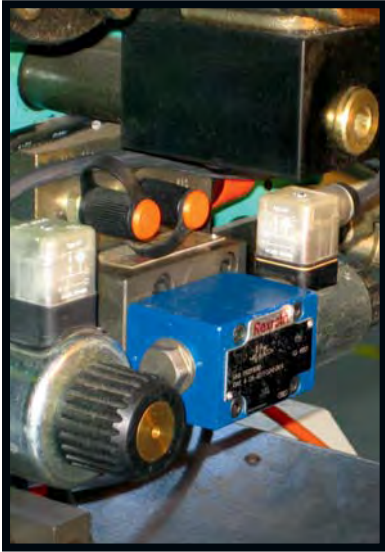

Order numbers:

Cable socket molded with LED function indicator and varistor voltage protection

- | | |
|-----------------------|----------------|
| • VAD 1A-1-3-226/2 M | Part No. 12136 |
| • VAD 1A-1-3-226/5 M | Part No. 12138 |
| • VAD 1A-1-3-226/10 M | Part No. 12135 |

Cable socket field-attachable, without protective circuit

- | | |
|------------|----------------------|
| • GDM 2016 | Part No. 934 395-100 |
| • GDM 3016 | Part No. 934 395-100 |

Device plug

- | | |
|--------------|----------------------|
| • GSA 2000 N | Part No. 932 967-100 |
| • GSA 3000 N | Part No. 932 968-100 |

Technical data:

- Number of pins: 2+PE, 3+PE (GDM, GSA), 2+2PE (VAD)
- Cable gland: M16 (GDM)
- Cable diameter/cross-section: 4,5–10 mm (max. 1.5 mm²)
- Rated voltage: AC/DC 24 V (VAD), AC/DC 250 V (GDM), AC/DC 400 V (GSA)
- Rated current: 4 A (VAD), 16 A (GDM, GSA)
- Protection class: IP65/67 (VAD), IP65 (GDM, GSA)
- Temperature range: -25°C up to +90°C (VAD), -40°C up to +125°C (GDM, GSA)
- Approvals: VDE (GDM, GSA), SEV/UL/CSA (GSA)



CA, CM, NR and G Series

The CA and CM series are utilized in the application areas of hydraulics, pneumatics, device and machine construction as well as in traffic control technology. An application that, in comparison to the others, is relatively new is photovoltaics.

The NR series is particularly versatile in power and control signal connections. It can be used even under the most extreme conditions, for instance in installations subject to strong vibrations.

The G series is designed for the harsh environment conditions of small drives, controls and sensors as well as for underground construction where small dimensions are required. In addition, it is suitable for use in actuators, sensing and power supplies.

Key features include:

CA/CM Series

- Available as 4 and 7 pin variants (incl. PE) for CA series and 3 to 17 pin variants (partly including PE) for the CM series
- Reliable transmission properties even under high stress such as vibrations
- High degree of resistance to external influences
- Especially easy installation due to few components
- CM series: compatible to metal connectors according to MIL-C-5015 and VG 95342
- Protection class up to IP67

NR Series

- Available as 7 and 12 pin variants (incl. PE)
- For voltages up to 250 V and currents up to 10 A
- Selection of plastic or metal housing for permanent solutions
- High degree of transmission safety due to continuous shielding against electro-magnetic radiation
- Protection class IP65

G Series

- Available in 7 to 17 pin variants (partly incl. PE)
- For voltages up to 250 V and currents up to 10 A
- Compact plug design with low space requirement
- Available as field-attachable or molded cable connector, as well as appliance connector
- Protection class IP65





ST Series

The ST series is perfectly suited for power supplies and signal transmission in all industrial installations and in machine construction. In addition, its use covers numerous applications in building automation. In the field of sun protection, the ST series is the de facto market standard.

Key features include:

- Available as 3 to 6 pin variants (incl. PE)
- For voltages up to 400 V and currents up to 16 A
- Dust and spray water protection for high resistance
- Approved by VDE and UL for worldwide application
- Additional safety due to metal bracket for security against loosening
- Protection class up to IP54

Order numbers:

Cable socket 3+PE

- STAK 3 N grey Part No. 932 140-106

Cable plug 3+PE

- STAS 3 N grey Part No. 932 143-106

Technical data:

- Number of pins: 3+PE
- Cable gland: PG11
- Cable diameter/cross-section: 6-10 mm (max. 1.5 mm²)
- Rated voltage: AC 400 V/DC 250 V
- Rated current: AC 16 A/DC 10 A
- Protection class: IP54
- Temperature range: -30°C up to +90°C
- Approvals: VDE, SEV, UL



Photovoltaic Connectors

SunCon Series

For module-to-module cabling or connecting individual solar panels, SunCon makes quick and easy connections for photovoltaic equipment that must withstand all weather conditions. This ensures practically maintenance free, highly reliable, efficient operation and outstanding low-loss power transmission.

Key features include:

- Quick and easy assembly of the connectors on site or already mounted ex factory
- Few component for ease and speed of assembly
- Optimal price/performance ratio
- Low transmission loss
- Comprehensive Installation Kit for site engineers available

Technical data:

- Temperature range: -40 °C to +85 °C
- Protection class: IP68
- Connectable solar-conductor-section: 2.5 – 4 mm² AWG 14/12
- Rated voltage: DC 1000 V
- Rated current: 30 A at 70°C/23 A at 85°C
- Suitable cables from 5 mm up to 6 mm diameter
- Contact resistance: <5 mOhm
- Locking torque: 150 Nm
- Inflammability class: Housing UL 94 V-0
- TÜV certified DIN V VDE 0126-3:2006 (for 4 mm²)

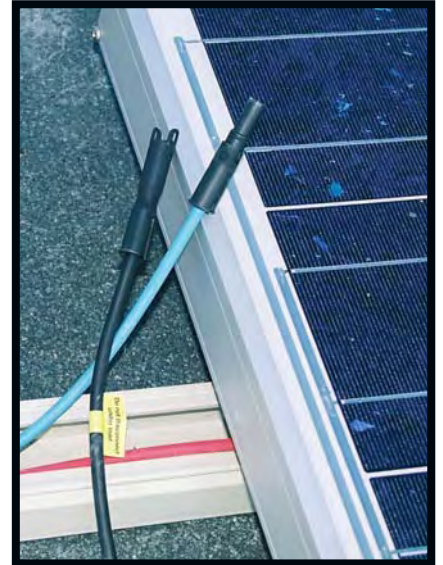

**Belden® – Wire and Cable Solutions for High Quality,
Top Performance and Total Reliability**

Belden offers cable and connectivity components (including fiber optics) for applications in Computer/Networks, CATV, Industrial, Entertainment and Security.

Belden is synonymous with high quality, high performance and reliability, all the time and in any market – broadcast, commercial networking, security, industrial, residential and many other applications. We have earned our worldwide reputation as an expert solutions provider. We make it our job to supply high performance, quality products and an innovative approach.

Belden offers the very widest range of signal transmission products. We provide all the data and back-up support necessary to help you to meet your requirements. We bring to market the very best in signal transmission technology – copper, optical fiber and wireless. And where needed, we offer complete systems.

Whilst we focus on providing the most cost effective solutions, Belden customers tell us that Belden is the brand they can trust and rely on for dependable signal transmission, all the time and in any market – broadcast, commercial networking, security, industrial, residential and many other applications. We have earned our worldwide reputation as an expert solution provider by supplying high performance, quality products and innovative solutions on which you can rely.

Belden offers the very widest range of signal transmission products. We provide all the data and backup support necessary to help you to make the right decision to meet your requirements and to solve your problems. With ongoing research and development to bring to market the very best in signal transmission technology – copper, optical fiber, wireless and so on, the product range has expanded to include complete system solutions including, for example: connectivity equipment, enclosures, cable raceways and racks.





Table of Content		Page
Industrial Cables		66–69
Multi-Conductor Cables		66
Paired Cables		66
Shipboard Cables		67
Building Security, Automation and Alarm Cables		67–68
Industrial Data Cables		68–69
Broadcast Cables		70–71
HDTV Fiber/Copper Composite Cables		70
Mobile Fiber Cables		70
Microphone Cables		71
Line Level Analog Audio Cables		71
Analog Multi-Pair Snake Cables		71
AES/EBU Digital Audio Cables		71
Video Triax Cables		71
Analog Video Cables		71
HDTV/SDI Video Cables		71
Residential Cables		72–73
Composite Cables		72
Coax Cables		72
Brilliance® VideoTwist® UTP Cables		73
Bonded-Pair Data Cables		73
Broadband Coax Cables		74–75
75 Ohm CATV Cables		74
50 Ohm Wireless Cables		75
Optical Fiber Cables		76–77
Interconnect Cables		76
Breakout Cables (BO)		76
Mini-Breakout Cables		76
Mobile and Tactical Fiber Cables		76
Central Loose Tube Cables (CLT)		77
Multi Loose Tube Cables (MLT)		77
Structured Cabling Solutions		78–89
Copper Systems		78–79
Belden 10GX System		80
System 4800LX		81
System 2400		82
System 1200		83
KeyConnect Patch Panel Series		84
The AngleFlex Patch Panel Series		85
GigaBIX Multi System		86–87
Optical Fiber Connectivity		88–89
Networking-Copper Cables		90–93
Bonded-Pair Cables		91
Unshielded Cables		92
Shielded Cables		93

Industrial Cables



Multi-Conductor Cables

Tough Cables That Keep Performing

This is the world's most comprehensive line of industrial cabling solutions – whether for networking factory floor equipment, hardware and controllers or relaying data between the control room, the engineering department and remote manufacturing sites or a combination of all the above. Belden industrial cables are designed to provide reliable communication between corporate headquarters and the plant, management and employees and everywhere in between.

Key Applications

- Signal transmission
- Communications
- Instrumentation & Control
- Single ended transmitters
- Transmission devices
- Multi-point networks
- Converters & Repeaters
- Computer EIA RS-232, RS-422 and RS-485 applications

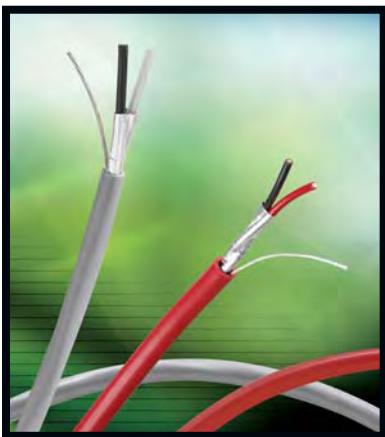

Paired Cables

Key Products

Multi-Conductor Cables

Multi applications demand multiple choices; with so many applications and systems, cable flexibility is vital, Belden® offers one of the broadest ranges of multi-conductor cables for a variety of applications. All products are approved to a range of standards including NEC, CMG, CEC.

Belden multi-conductor cables are offered in a wide variety of gauge sizes, dimensions, insulation materials, shielding configurations and jacketing materials. Shielding configuration options include the innovative and patented aluminium/polyester foil Beldfoil® shield for extra strength, insulation and 100% shield coverage, or an overall Beldfoil® shield with an additional tinned copper braided shield for optimal protection. Jacketing and insulating materials for increased temperature, chemical resistance, mechanical and plenum environments are also offered for specific application requirements.

Paired Cables

For balanced signal transmission and lower cross talk, Belden offers a broad range of shielded and unshielded twisted pair cables with proven performance in installations worldwide. The improved noise immunity of twisted pairs generally permits higher data speeds than multi-conductor cables, ensuring optimal performance in a multitude of applications.

Belden paired cables can be supplied in a wide variety of pair counts, gauge sizes, insulation materials, shielding configurations and jacketing materials, all with convenient put-up lengths to suit the specific application. Overall and individual pair's shielding configuration options include the innovative and patented aluminium/polyester foil Beldfoil® shield for extra strength, insulation and 100% shield coverage, or an overall Beldfoil® shield with an additional tinned copper braided shield for optimum protection.

Belden paired cables are approved to a range of standards including NEC, CMG, CEC. Plenum versions are also available for many of the cables within Belden's paired cable range.



Shipboard Cables

Belden's diverse Shipboard cable line is designed to implement a wide range of shipboard audio, video, security, networking and control applications. The range of low smoke zero halogen Shipboard cables deliver high-end audio and video quality on private yachts and commercial ships to enhance consumer enjoyment, ship-board safety and communications.

The copper/fiber-based series comprises:

- Audio, Control and Instrumentation Cables
- Broadband Coaxial Cables
- Precision Video Cable for Analog and Digital
- DataTwist® Networking Cable
- Security Composite Cables
- Fiber Optic Cables



All products have independent, third-party approval by the ABS. The American Bureau of Shipping is the leading international classification society devoted to promoting the security of life, property and the marine environment through the development and verification of standards for the design, construction and operational maintenance of marine-related facilities.

Belden's line of Shipboard cables also complies with industry standards IEEE 45, and applicable sections of IEC 60092-376 for low smoke and zero halogen.

Building Security, Automation and Alarm Cables

Today's demands are constantly changing the boundaries of cable technology. Nowhere is the demand for uncompromising quality and leading-edge-technology more critical than in the increasingly complex fields of security and alarm systems and audio/visual applications. Belden offers a full complement of reliable and cost-effective low voltage electronic multi-conductor and coaxial cables, all designed to satisfy the demands of designers, developers and installers alike.

Security and Alarm Cables

Suitable for a wide range of applications, including security systems, sound and intercom systems, power-limited controls, fire and burglar alarm systems, single-line telephones, and more.



Security and Surveillance CCTV Cables

To support a wide range of facility monitoring, security and asset protection applications, including closed-circuit television (CCTV), CCTV plus audio or power, CCTV Pan/Tilt/Zoom (PTZ) camera control, and card reader/sensor systems.

Fire Alarm Cables

For commercial fire alarms, monitoring and detection systems, audio, control and notification circuits.



Access Control Cables

Suitable for a wide range of security and access control applications, including security control panels, junction boxes, door control, card readers and lock power systems.

Banana Peel PTZ Composite Cables

Consisting of RG-59/U coax, twisted pair and multi-conductor cables, these are ideal for CCTV plus audio or power, and PTZ CCTV camera control applications. All feature Belden's unique Banana Peel jacketless construction, which provides fast, easy installation.



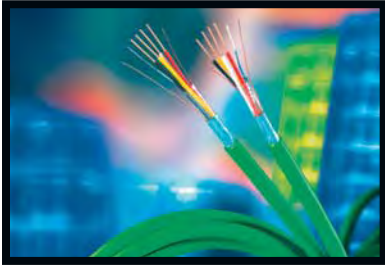

KNX/EIB approved cables

Communication and Control Cables

Used in a wide range of applications such as security systems, pro audio, sound and intercom systems, annunciators and power-limited controls. Also featured as part of this range are KNX/EIB approved cables and LonWorks® cables for use with the LonWorks networking platform.

Circuit Integrity Cables

Specifically designed for use during severe fires where a low-smoke, zero-halogen cable is required to maintain circuit integrity.

Industrial Data Cables

High performance cabling solutions have changed the face of modern production facilities, manufacturing processes and the industrial infrastructure. Productivity depends upon seamless data communication and automation systems now more than ever, industry today depends on reliability, long life and superb performance, often in the toughest of environments.

For reliable communication from the factory floor, process equipment or devices to their controllers, relaying data between the control room, engineering department, remote manufacturing sites and more, Belden's comprehensive range of Industrial Data Solutions® comprises cables for all types of Fieldbus and Industrial Ethernet applications.



Cables for PROFIBUS applications

Belden® Industrial Network Protocol Solutions, Fieldbus Network Protocols

PROFIBUS is the world's most popular Fieldbus system with application specific profiles such as:

- PROFIBUS DP – optimized for factory automation
- PROFIBUS PA – optimized for process automation

To meet the specifications of PROFIBUS DP, Belden has developed a range of 150-Ohm Twinax (twisted pair) cables. These cables match the impedance of the factory automation systems, allowing for maximum signal transmission, while their overall Beldfoil® shield plus a 65% tinned copper braid are incorporated for maximum shielding effectiveness.

For PROFIBUS PA, Belden offers an 18 AWG stranded twisted pair cable with an overall Beldfoil® shield and an intrinsically safe (IS) blue jacket.

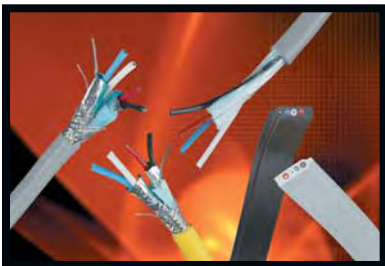

DeviceBus® cables for ODVA DeviceNet systems

DeviceBus® Cables for ODVA DeviceNet Systems

Belden provides an extensive line of DeviceBus® cables which are typically designated as either Class 1 (600 V) or Class 2 (300 V) "Thick," "Thin," or "Mid" cable. They can be used for either trunk or drop applications, dependent on the system speed and overall end-to-end distance.

ControlBus Cables for ControlNet™ Systems

To ensure that Belden's ControlBus cables meet the high-speed, time-critical requirements for the operation of ControlNet™ factory-floor systems, these Low-Loss RG-6/U Type coaxes incorporate a Duobond® Quad Shield for maximum signal integrity and run length.

For the full range of Belden's leading line of cable solutions for industrial communications systems, including Blue Hose®, Modbus, and Lonworks cables to name but a few, visit www.belden-emea.com.

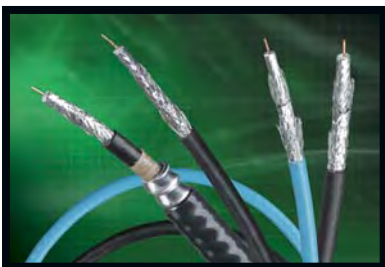

ControlBus cables for ControlNet™ systems



Industrial Ethernet Network Protocols

The Belden range of Fieldbus cables is complemented by an extensive range of Industrial Ethernet cabling offering the same superior performance for Ethernet based applications.

With high foil and braided shield coverage to maintain signal integrity in the industrial 'noisy' environment, Belden Industrial Ethernet cables ensure product reliability and consistent performance.

Innovative shielding techniques ensure maximum protection in EMI (Electromagnetic interference) and RF (Radio frequency) spectrums.

PROFINET is the leading Industrial Ethernet standard for automation, the Belden range of PROFINET compliant cables is designed to withstand the entire spectrum of environmental and mechanical hazards, from temperature extremes and sunlight, to solvents, oils, chemicals and moisture.

Star quad twist cable design with a Green RAL 6018 cable jacket, the range includes cables for:

- Type A (Stationary) applications
- Type B (Flexible) applications
- Type C (Trailing or Torsion) applications

Industrial Ethernet Cables

For standard Industrial Ethernet and EtherNet/IP™ variants, Belden offer a range of 4 pair and 2 pair cable designs with Cat 5e and Cat 7 transmission performance, available with solid and stranded conductors to suit the full spectrum of industrial applications.

Belden's high performance industrial cabling is designed and approved to international standards for quality and safety assurance in the global environment.

To meet the particularly harsh conditions found in such industries as petrochemical, pharmaceutical, mining, power generation, wastewater treatment, pulp and paper, food processing and transportation, these cables are also available with multiple armoring and jacketing options.

Belden offers the most comprehensive, range of industrial cable products on the market today. Whether for automation, data exchange, interconnection or full networks, Belden has the right solution to keep your data – and your business – on the go.

In addition, Belden offers a wide variety of Variable Frequency Drive (VFD) cables, Control and Instrumentation cables and the Infinity® line of flexible automation cables, for the full range, visit www.belden-emea.com.



Industrial Ethernet

Belden's Industrial Ethernet cable range has been developed to achieve optimum network performance when used in conjunction with Hirschmann™ switches. In addition to this, Belden Industrial Ethernet cables are perfectly capable of offering the best possible network performance when used in any Industrial Ethernet application.

Broadcast Cables



The Broadcasters' Choice

Perhaps there is no other industry which values reliability so highly because inferior broadcast performance has immediate, far-reaching and embarrassing results. Cable performance means assured product quality, absolute signal integrity and no system downtime. Did you watch television last night or listen to the radio this morning? Chances are the link were made with Belden® cable – and with so much dedication to development and innovation, the link with Belden increases. Belden products offer the highest performance in both critical field applications (where cable is dragged, crunched and trodden on) and permanent studio installations (where long runs are all important). Belden cables are an important link in network and cable broadcasts (e.g. BBC, CNN, NBC, NOB, ZDF), film studios (Lucas film) and corporate broadcasting (USA Today, Merrill Lynch).



Key Applications

- Television monitors
- LCD screens
- Microphones
- Lighting, DMX
- VGA on large screens
- Animation, editing
- Loudspeakers
- HD/SDI

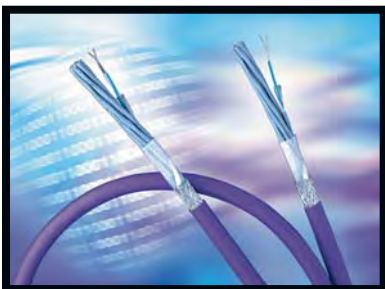

Key Products

Belden's commitment to product innovation and technical excellence in the broadcast industry has resulted in a range of reliable audio and video cabling products called Brilliance®. Known for sound and picture brilliance and improved signal integrity, Brilliance® embraces all Belden audio/video products.

HDTV Fiber/Copper Composite Cables

Designed specifically for high-definition cameras, these composite cables can multiplex audio and video signals and power. The cables meet all the requirements of the SMPTE 311 standard developed by the Society of Motion Picture and Television Engineers (SMPTE). They are also compatible with industry standard SMPTE 304M connectors.

Mobile Fiber Cables

Broadcast truck owners and operators always appreciate the chance to reduce the size and/or weight of any component being carried. Lighter weight Belden mobile optical fiber cable with PUR jacket is extreme rugged and designed for despooling and respooling.



Microphone Cables

Belden microphone cable is used for connecting low level microphones. Key properties of microphone (MIC) cables are ruggedness, flexibility, flex life and interference immunity. Low impedance MIC cables use balanced 2-, 3- or 4-conductor (quad) designs.

Line Level Analog Audio Cables

Belden analog audio cables are used for connecting line level audio equipment, in either permanent or semi-permanent installations. They consist of one or two individually foil-shielded, twisted pairs. Once installed, they are not intended to be moved while in operation. For cables that are in motion during use, refer to the microphone and musical instrument cable section in this catalog. Belden's analog audio cable range consists of several designs to handle a variety of audio applications.

Analog Multi-Pair Snake Cables

Specially designed for the broadcast industry, Belden's full family of multi-pair audio "Snake" cables feature different options and constructions for virtually every application.

AES/EBU Digital Audio Cables

The specification for digital audio was developed jointly by the Audio Engineering Society (AES) & European Broadcast Union (EBU). The key difference between twisted pair specifications for digital audio cable and standard analog audio cable is the impedance specification. AES/EBU, with its broad tolerance, allows cables with impedances from 88 Ohm to 132 Ohm to be used. Standard analog audio cable impedance is 45 Ohm to 70 Ohm. This amount of potential mismatch can result in signal reflections and jitter, causing bit errors at the receiver. For this reason, Belden recommends 100 to 120 Ohm shielded twisted pair cables.

Video Triax Cables

Video Triax cables are used to interconnect video cameras to related equipment. They contain two isolated shields and a solid or stranded center conductor. Isolated shields allow the triax to provide multiple functions over one cable through multiplexing techniques. Applications include DC power to camera, intercom to operator, teleprompter feeds, monitoring feeds and even automatic or robotic functions.

Analog Video Cables

Standard video cables are typically used in non-critical video applications such as video equipment rack wiring, Closed Circuit TV (CCTV), Master Antenna TV (MATV) and color or monochrome video monitor hook-ups.

HDTV/SDI Video Cables

HDTV/SDI video cables usually have solid center conductors and dual shields. The dielectrics can either be foamed PE or for better crush resistance foamed HDPE insulation. Tighter impedance and attenuation tolerances, superior Return Loss (RL) specifications and improved shielding give precision video cables their no-compromise performance.



Residential Cables



A House is More than a Home

The intelligent home is here – a living, working, entertaining, learning place. Cables tie the whole experience together providing high quality, superior performance, proven reliability and wide choice to meet all the needs of changing technology and the demands of the discerning consumer.

Key Applications

- Home office
- Audio/video
- Climate control
- Window shade automation
- Lighting



Key Products

Every Belden® cable (and connector) is subject to the industry's most rigorous quality control process. Individual or single application cables are available for any data, video, audio, control or security need, including:

- Category 5e UTP and optical fiber cables for multimedia, voice, video and data use.
- Coax cables for HDTV, DBS, CATV, SVHS, CCTV, S-Video, SPIF and cable modem applications.
- High-conductivity (oxygen-free) speaker cables for audio distribution.
- Paired, unshielded cables for control applications.
- Non-category, Cat 5e and Cat 6 low skew performance UTP cables for video signals over twisted pair cables.
- One-piece connectors and tools that facilitates fast and easy cable connection.



Composite Cables – Without a Jacket

Composite cables simplify a multiple use installation by combining Belden data cables, coaxial cables, paired and multi-conductor cables and fiber optic cables in a single-pull product. Installation of these cables means that residential properties will be 'future-proof' – ready to embrace the next generation of home entertainment and new technology. This makes a property more saleable and more attractive to the buyer.

Belden Banana Peel® composite cables feature a patent-pending design that eliminates the need for an overall jacket, making the cables easy to handle, identify, pull and terminate. All that is necessary is to peel the cables off the center spline. These cables are increasingly used for multiple installations in new homes.

Coax Cables with Belden's Exclusive Duobond® Plus Shielding

Duobond® Plus consists of a Duofoil® II (foil tape) surrounded by an 80% braid and an outer layer of foil with a shorting fold. This unique construction provides optimum shielding effectiveness.



Brilliance® VideoTwist® UTP Cables

To meet the new video/data UTP requirements, Belden has designed a new series of cables. High resolution videos require high performance cables that have low signal skew and low return loss. Typically, these systems use bundled coax for the cable interconnection. Increasingly, however, system designers are turning to unshielded twisted pair (UTP) transmission equipment to distribute component RGB video because UTP is cheaper than coax. UTP cables also mean that the same cable can be used for premise LAN wiring – eliminating the need for two separate cables.

Brilliance VideoTwist® UTP cables offer the best low skew and return loss performance in the marketplace and are designed for quality video applications – plus they meet applicable TIA/EIA standards for data transmissions. The cables dramatically reduce installation costs but retain the appearance, feel and familiarity of a standard category twisted pair cable.

Bonded-Pair Data Cables to Provide the Assurance of Installable Performance™

With patented bonded-pair design, the cables are able to withstand the rigors of a typical installation without any degradation in performance. This means, for example, that the Cat 5e cable will not only meet the Cat 5e specifications before installation but, more importantly, it will continue to meet them after installation.



Broadband Coax Cables



Bringing People Closer

Today, wireless communication is part of everyone's life as we increasingly communicate with each other and source information through networks such as cellular phones, TV broadcasting and WLAN. The strength of Belden® is to anticipate market demands, adapt, invent and innovate to meet changing needs for increased bandwidth and easy installation.

This means that the cables need more protection from electromagnetic interference for multi-media applications (telephony, internet or video-on-demand) and need to support interactive services like Two-Way-TV (TWTv) need return-path capable cables, according to class A.

Key Applications

- Cable television systems
- Satellite direct broadcast systems
- Digital terrestrial-based systems



Key Products

Belden offers one of the most comprehensive, economical and modern ranges of reliable 75 Ohm and 50 Ohm coaxial cable products on the market. All Belden CATV coaxial cables comply with the European standard and international quality and safety standards. The products are designed according to the international standard IEC 1196 for Radio Frequency Cables and the European standard EN50117.

75 Ohm CATV Cables

The 75 Ohm CATV offering includes trunk, distribution, drop and headend cables. The distribution and drop coaxes feature Belden's innovative, high-performance Duobond Plus® shielding and/or Belden's Duobond® II shield. Offering longer life expectancy and superior electrical/mechanical performance in hardline the cables are designed to withstand all kinds of environmental elements. All products are engineered to withstand jacket damage and corrosion and to optimize faster and easier installation.

- **Duobond Plus®**

Belden's Duobond Plus® has a three-shield construction consisting of a Duobond® II (foil tape) surrounded by a braid and an outer layer of foil with a unique shorting fold which creates the effect of a solid metal conduit. This combination offers superior high frequency shielding when compared with traditional Quad shields. Duobond Plus® is faster to install, because the outer tape shield is bonded to the jacket and can be stripped easily in one step. Furthermore, this construction gives Duobond Plus® a smaller bending radius, greater flexibility and, compared to quad shielded coax, a 10 percent weight reduction.



- **Duobond® II**

The foil/braid type combines Duobond with an outer braid. This is added to provide greater protection against interference and to increase overall tensile strength. The combination foil/braid shield combines the advantages of 100% foil coverage with the strength and low DC resistance of the braid.

- **FRNC/LSNH**

Belden has developed low-smoke (LS), fire-retardant (FR) and zero-halogen (ZH) cables. These three properties are annotated as FRNC/LSNH (also known as FRNC/LSZH).

50 Ohm Wireless Cables

Belden's 50 Ohm RF cables provide best-in-class transmission performance and superior EMI/RFI shielding for greater noise reduction. They are ruggedly constructed and designed to be flexible for easy installation and routing.

Features include:

- **Lowest Loss**

Belden's 50 Ohm RF cables provide the lowest loss of any land mobile radiotype coaxial cables on the market (from 5% to 10% lower, depending on the design and frequency). The result is better signal transmission at the same distance, or longer transmission distance with less attenuation. All cables are 100% sweep tested to 6 GHz to assure performance in future high frequency Applications.

- **Low VSWR**

VSWR is guaranteed to be 1.25:1 maximum over all frequencies (RL = -19 dB).

- **High Velocity of Propagation**

The foamed high-density polyethylene insulation provides the highest velocity of any land mobile radio-type flexible coaxial product on the market. The high-density material properties provide superior crush resistance to minimise impedance variations and return loss, ensuring high performance both before and after installation.

- **Excellent Phase Stability**

Belden's 50 Ohm RF cables exhibit excellent phase stability over both temperature changes and flexing, resulting in improved signal integrity and reliability.

- **Superior RF Shielding**

The combination foil/braid shield provides in excess of 100 dB of effective EMI/RFI shielding.

- **Connector Compatibility**

The RF series cables are compatible with all standard land mobile radio-type connectors, including Times Microwave, RF Industries, Amphenol, Trompeter, EF Johnson and others.

- **Conformable Coax**

For applications requiring low VSWR and high shield effectiveness, Belden's complete product range of 50 Ohm conformable coax cables offers unequalled performance. These patented cables serve as a replacement for semi-rigid cables and, unlike semi-rigid, they are hand formable.



Optical Fiber Cables



Advanced Networks Need Advanced Technology

Today's advanced networks are diverse and very varied and almost always complex. The right way ahead is to future-proof these networks and take precautions to protect them against anything that will create problems, damage or disrupt. That means matching the right hardware with the right cabling to guarantee performance – and that means choosing fiber optic cable. This type of cable has become essential for bringing light-speed communication to hospitals, corporate campuses, educational facilities and other projects.

Key Applications

- Closed circuit television
- Network circuitry
- Factory automation
- Major commercial networks
- Video conferencing
- Medical imaging
- CAD/CAM

Key Products

Interconnect Cables

Featuring semi-tight buffer and tight buffer technology for easy cable preparation during termination.

- Semi-tight buffered fiber cables are available in dry constructions with excellent strippability properties (≤ 100 cm).
- Tight-buffered fiber cables are dry constructions and designed for easy stripping in cable preparation (≤ 10 cm).

Breakout Cables (BO)

Breakout cables are the preferred choice for direct termination methods. Each numbered fiber subunit is protected by a layer of aramid yarn and encased in a FRNC/LSNH jacket. The individual subunits are cabled and then jacketed with a flame resistant FRNC/LSNH compound. Each fiber uses either the tight buffer technology or semi-tight buffer technology for excellent fiber stripping.

Mini-Breakout Cables

These cables offer dry constructions with semi-tight or tight buffer technology for easier fiber stripping during cable preparation. They are perfect for both indoor and indoor/outdoor use.

Mobile and Tactical Fiber Cables

The semi-tight buffer technology is designed for rugged field applications and will withstand temperature extremes and vehicle traffic. Repeating bending is > 500000 times according to IEC 60794-1-2-E6. For indoor use, it has flame retardancy acc. IEC 60332-2.



Central Loose Tube Cables (CLT)

Central loose tube cables are designed either for indoor/outdoor application or outdoor use only as direct burial, duct and outside tray. For better performance, Belden® only uses (non-dripping and silicone-free) jelly-filled loose tubes. The central loose tube series has a polyethylene or halogen-free jacket. These cables have been updated with a longitudinal watertightness swellable yarn for weather-resistance.

- Standard and improved rodent protection designs are available with up to 24 fiber counts.
- Central loose tube cables are also available with Corrugated Steel Tape (CST), Steel Wire Armor (SWA) or Fiber Reinforced Plastic armor (FRP) to protect the whole cable from mechanical damage and rodents.

Multi Loose Tube Cables (MLT)

Multi loose tube cables, with no aquagel between the tubes (dry core) or with jelly-filled cable core, are designed for direct burial, duct, outside tray and aerial applications. For better performance, Belden only uses (non dripping and silicone-free) jelly-filled loose tubes. Tubes and (when necessary) blind elements are S-Z stranded around the central element. The multi loose tube series has a High-Density-Polyethylene (HDPE) or halogen-free jacket. These cables have been updated with water-blocking aramid or glass yarn. Standard and improved rodent protection designs are available with high fiber counts up to 216 fibers.

- The multi loose tube cables are also available with Corrugated Steel Tape armor (CST) for total protection.
- Longitudinal water tightness: to guarantee longitudinal water tightness acc. to IEC 60793-1-2-F5, Belden uses swellable yarns and/or tapes or filling compound.

Options:

- All loose tube cables with additional PA (nylon) jacket for termite/rodent protection, improved chemical resistance and reduced friction.
- Replace PE jacket by Orgalloy or TPU to improve chemical resistance.

All cable constructions are in accordance with IEC 60793, and have been tested according to IEC 60794.

Rodent Protection

The Belden fiber optic cable line offers two different kind of rodent protection:

- **Standard Rodent Protection**
Optical fiber cables with glass reinforced yarns for strength also provide normal protection against rodents.
- **Improved Rodent Protection**
Belden offers cables with improved rodent protection. These have extra glass reinforced yarns or an extra layer of nylon (polyamide). The idea behind this is that rodents will look for the easiest route. Rodents will bite anything in order to keep their teeth in proper shape but will only continue if they feel comfortable. With the nylon layer or "glass" yarns they will normally stop and move elsewhere.

It is important to note that non-armored cable never guarantees a 100% protection against rodents. Armored cables (CST, SWA, FRP) are heavy rodent protected.



Structured Cabling Solutions

Copper Systems

What constitutes a system?

- Cables to physically link the computer and networking devices to each other.
- Connectors to terminate the cables and allow easy plug-in/plug-out attachment.
- Cross-Connect or patch panel fields to allow easy re-deployment of the cables when moves, adds and changes in the network are required.

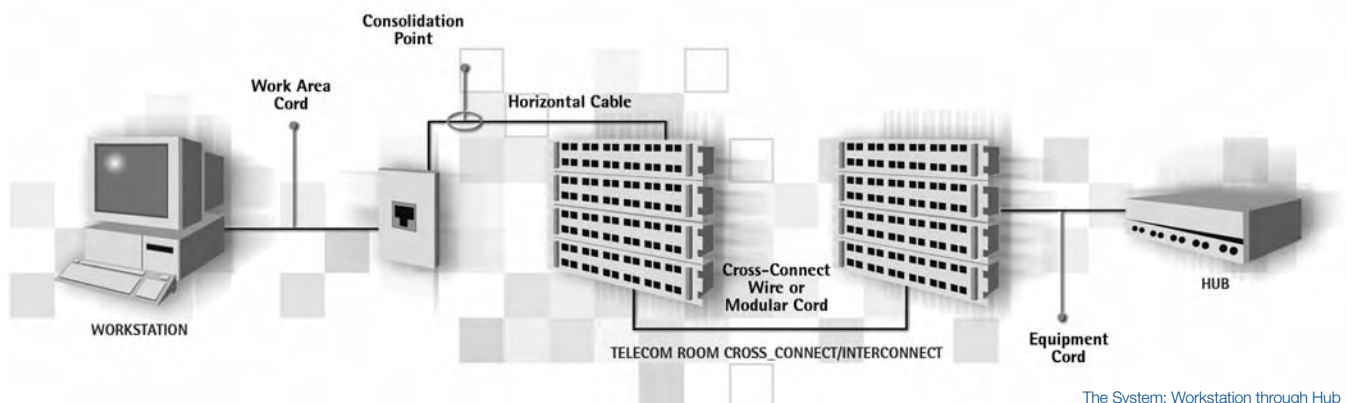

The System: Workstation through Hub

Why Belden? Belden Goes Beyond the Standard!

Each of the copper cabling components depicted on the following pages is vital to the overall performance of the network, but to achieve optimum network performance you should consider Belden IBDN end-to-end structured cabling systems. Belden IBDN copper structured cabling systems are recognized the world over for their high quality since they are the result of both Belden's exceptional design and manufacturing expertise and the system's ability to outperform the standards.

What are the credentials of a quality system supplier?

- Credibility/Industry Standing
- System Offerings
- Customer Care
- Business Partners
- System Certification & Warranty Program

Dimensions that define system excellence:

- Quality Components
- Quality Design
- Quality Installation & Service

Belden Systems vs Standards Category Performance

The Belden systems offering are wide, and covers all the current required categories. The Belden approach is to exceed standards. The below table provides an overview of the Belden systems and their performances:

Belden System	Bandwidth (Mhz)	Category Standard Performance	Standard Bandwidth (Mhz)	Belden Headroom Offered	Guaranteed Data Rates (Gb/s)
10 GX	625	Cat 6a	500	25%	10.0
4800	300	Cat 6	200	33%	4.8
2400	250	Cat 6	200	25%	2.4
1200	160	Cat 5e	100	60%	1.2



If Leading-edge Communication Systems are an Element of Your Strategy – Install Belden!

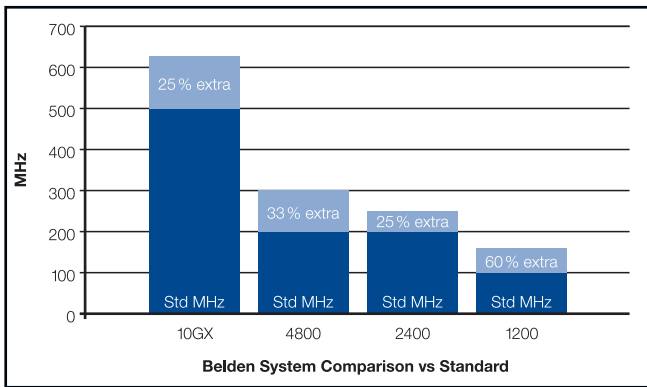

The figures shown represent the % increase above the 1dB gain required in the (SNR) PSACR-N at the appropriate required frequency.

- Belden Bandwidth MHz Advantage v's Standard
- Standard Bandwidth MHz

Performance Enabling Technologies

To deliver market leading performance, Belden systems utilise Performance-Enabling Technologies. For Example:

- **The Matrix IDC™ (10 GX system) Module**
This is designed to substantially eliminate the issue of Alien Crosstalk between the systems modules.

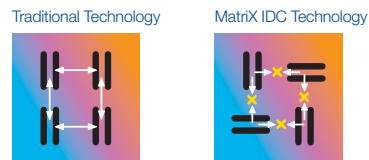

- **X-Bar™ Technology**

The X-Bar is a control device that enables the accurate positioning of each UTP pair before the pair is terminated on the 10GX module's IDC pins.



Belden Solutions



Belden® 10GX System

Description	Belden Part Number					
	Grey	Almond	White	Black	Orange	Red

10GX Modular Jack

Category 6a						
10GX Modular Jack, T668A/B, MDVO-Style	AX102269	AX102270	AX102271	AX102272	AX102273	AX102274
10GX Modular Jack, T668A/B, Key-Connect	AX102280	AX102281	AX102282	AX102283	AX102284	AX102285
		Yellow	Green	Blue	Purple	Brown
10GX Modular Jack, T668A/B, MDVO-Style		AX102275	AX102276	AX102277	AX102278	AX102279
10GX Modular Jack, T668A/B, Key-Connect		AX102286	AX102287	AX102288	AX102289	AX102290

Description	Red	Yellow	Green	Blue	Grey	White	Black
-------------	-----	--------	-------	------	------	-------	-------

10GX Modular Cord

Category 6a, 4-pair, 23 AWG solid, T668A/B - T668A/B, CMR							
0.6 m (2.0 ft.)	AX360043	AX360055	AX360019	AX360013	AX360025	AX360049	AX360007
1.2 m (4.0 ft.)	AX360044	AX360056	AX360020	AX360014	AX360026	AX360050	AX360008
2.4 m (7.0 ft.)	AX360045	AX360057	AX360021	AX360015	AX360027	AX360051	AX360009
3.0 m (10.0 ft.)	AX360046	AX360058	AX360022	AX360016	AX360028	AX360052	AX360010
4.6 m (15.0 ft.)	AX360047	AX360059	AX360023	AX360017	AX360029	AX360053	AX360011
7.6 m (25.0 ft.)	AX360048	AX360060	AX360024	AX360018	AX360030	AX360054	AX360012

Description	T668A	T668B
-------------	-------	-------

10GX Pigtail

Category 6a		
4.6 m (15.0 ft.)	AX360265	AX360269
7.6 m (15.0 ft.)	AX360266	AX360270
10.6 m (15.0 ft.)	AX360267	AX360271
15.0 m (4.0 ft.)	AX360268	AX360272

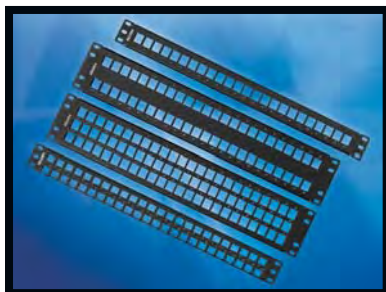

KeyConnect Patch Panel

Description	Belden Part No. – Titanium
-------------	----------------------------

10GX Patch Panel

Category 6a	
10GX KeyConnect Patch Panel, 24-port, 1U	AX103254
10GX KeyConnect Patch Panel, 48-port, 2U	AX103256
10GX Ultra-High Density Patch Panel, 48-port, 1U	AX103264

10GX Nonbonded-Pair, 4-pair, 23 AWG, LSNH, Category 6A

Belden Part Number	Color	Length	Packaging	No. of Packages per Pallet	Total Length per Pallet
10GX24.07305	Purple	305 m (1000 ft.)	Spool	18 reels/pallet	5490 m (18000 ft.)

10GX Bonded-Pair, 4-pair, 23 AWG, LSNH, Category 6A

Belden Part Number	Color	Length	Packaging	No. of Packages per Pallet	Total Length per Pallet
10GX44.07305	Purple	305 m (1000 ft.)	Spool	18 reels/pallet	5490 m (18000 ft.)



System 4800LX

The Belden IBDN system 4800LX combines the power and performance of our PS6 connectivity products with our break-through series 4800LX UTP cables to provide industry's first true end-to-end 300 MHz cabling system.

Systems components include: GigaFlex 4800LX unbonded-pair UTP Cables, DataTwist® 600e bonded-pair UTP cables, GigaBIX cross-connect systems, PS6+ patch panels (including fully loaded and modular versions) and related patch cords, outlets, modules, faceplates and adapters.

Description	Belden Part Number
Belden IBDN System 4800LX, Modules	
GigaFlex PS6+ Module	
T568A/B, White	AX101320
T568A/B, Black	AX101321

AX101067 GigaFlex PS6+ Module

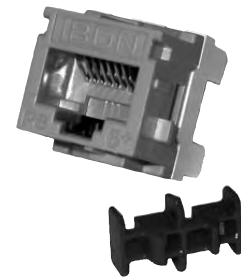

Description	Belden Part Number
Belden IBDN System 4800LX, Patch Panels	
GigaFlex PS6+ Patch Panel	
GigaFlex PS6+ Patch Panel, 1U, 24-port, Black, loaded	AX101611
GigaFlex PS6+ Patch Panel, 2U, 48-port, Black, loaded	AX101613
Flex Patch Panel, 1U, 24-port, Black, unloaded	AX101571
Flex Patch Panel, 2U, 48-port, Black, unloaded	AX101458

AX101613 GigaFlex PS6+ Patch Panel



Flexible KeyConnect Panels also available, please refer to page 84

Description	Belden Part Number					
	Blue	White	Grey	Green	Red	Yellow

Belden IBDN System 4800LX, Modular Cords						
GigaFlex PS6+ Modular Cord, LSZH 4-pair, 23 AWG solid, T568B - T568B						
0.5 m (1.6 ft.)	AX102356	AX102350	AX102392	AX102544	AX102550	AX102556
1.0 m (3.3 ft.)	AX102357	AX102351	AX102393	AX102545	AX102551	AX102557
2.0 m (6.5 ft.)	AX102358	AX102352	AX102394	AX102546	AX102552	AX102558
3.0 m (10.0 ft.)	AX102359	AX102353	AX102395	AX102547	AX102553	AX102559
5.0 m (16.4 ft.)	AX102360	AX102354	AX102396	AX102548	AX102554	AX102560
10.0 m (33 ft.)	AX102361	AX102355	AX102397	AX102549	AX102555	AX102561

AX350061 GigaFlex PS6+ Modular Cord



Description	Belden Part Number		
	Blue	White	Purple

Belden IBDN System 4800LX, Cables			
Beyond Category 6			
GigaFlex 4812LX Cable, CMR, 23 AWG, 305 m Spool	4812.06305	4812.09305	-
GigaFlex 4813LX Cable, CMP, 23 AWG, 305 m Spool	4813 D151000	4813 0091000	-
GigaFlex 4824LX Cable, LSZH, 23 AWG, 305 m Spool	-	-	4824.07305
DataTwist® 600e, CMR, 23 AWG, 305 m Reel	7852A 0061000	7852A 0091000	-
DataTwist® 600e, CMP, 23 AWG, 305 m Reel	7852A D151000	7852A 0091000	-

4812.06305 GigaFlex 4812LX Cable

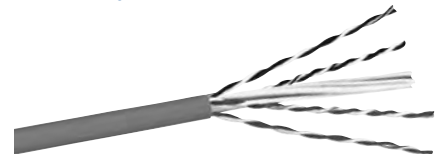

This systems overview page is intended to give you a basic list of the main components used in the system. For a more complete listing of product options and for more detailed product information go to belden-emea.com.

AX101067 GigaFlex PS6+ Module

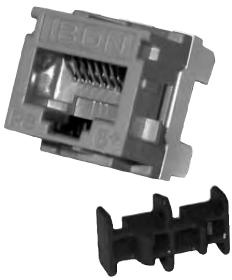

AX101613 GigaFlex PS6+ Patch Panel



AX350061 GigaFlex PS6+ Modular Cord



2424.07305 GigaFlex 2424 Cable

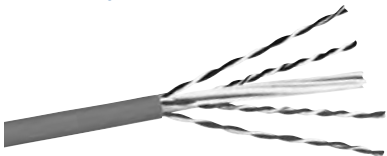

This systems overview page is intended to give you a basic list of the main components used in the system. For a more complete listing of product options and for more detailed product information go to belden-emea.com.

System 2400

The Belden® IBDN system 2400 installations provide the additional throughput and enhanced error-free performance needed to support high-traffic and high-bit-rate applications. It delivers 250 MHz of user bandwidth as well as support for data rates up to 2.4 gigabits per second.

Systems components include: GigaFlex 2400 unbonded-pair UTP cables, MediaTwist® bonded-pair UTP cables, GigaBIX cross-connect systems, PS6+ patch panels (including fully loaded and modular versions) and related patch cords, outlets, modules, faceplates and adapters.

Description	Belden Part Number
-------------	--------------------

Belden IBDN System 2400, Modules

GigaFlex PS6+ Module	
T568A/B, White	AX101320
T568A/B, Black	AX101321

Description	Belden Part Number
-------------	--------------------

Belden IBDN System 2400, Patch Panels

GigaFlex PS6+ Patch Panel	
GigaFlex PS6+ Patch Panel, 1U, 24-port, Black, loaded	AX101611
GigaFlex PS6+ Patch Panel, 2U, 48-port, Black, loaded	AX101613
Flex Patch Panel, 1U, 24-port, Black, unloaded	AX101571
Flex Patch Panel, 2U, 48-port, Black, unloaded	AX101458

Flexible KeyConnect Panels also available, please refer to page 84

Description	Belden Part Number					
	Blue	White	Grey	Green	Red	Yellow

Belden IBDN System 2400, Modular Cords

GigaFlex PS6+ Modular Cord, LSZH 4-pair, 23 AWG solid, T568B - T568B						
0.5 m (1.6 ft.)	AX102356	AX102350	AX102392	AX102544	AX102550	AX102556
1.0 m (3.3 ft.)	AX102357	AX102351	AX102393	AX102545	AX102551	AX102557
2.0 m (6.5 ft.)	AX102358	AX102352	AX102394	AX102546	AX102552	AX102558
3.0 m (10.0 ft.)	AX102359	AX102353	AX102395	AX102547	AX102553	AX102559
5.0 m (16.4 ft.)	AX102360	AX102354	AX102396	AX102548	AX102554	AX102560
10.0 m (33 ft.)	AX102361	AX102355	AX102397	AX102549	AX102555	AX102561

Description	Belden Part Number		
	Blue	White	Purple

Belden IBDN System 2400, Cables

Category 6			
GigaFlex 2412LX Cable, CMR, 24 AWG, 305 m box	2412.06A305	2412.09A305	-
GigaFlex 2413LX Cable, CMP, 24 AWG, 305 m box	2413 D15A1000	2413 009A1000	-
GigaFlex 2424LX Cable, LSZH, 24 AWG, 305 m box	-	-	2424.07305
CMR, UTP Bonded-Pair, 23 AWG, 305 m box	7812E.01U305	-	-
LSNH, UTP Bonded-Pair, 23 AWG, 305 m box	7812ENH.01U305	-	-



System 1200

The Belden IBDN system 1200 installations provide the additional throughput and enhanced error-free performance needed to support high-traffic and high-bit-rate applications. It delivers 160 MHz of user bandwidth as well as support for data rates up to 1.2 gigabits per second.

Systems components include: GigaFlex 1200 unbonded-pair UTP cables, DataTwist® 350 bonded-pair UTP cables, GigaBIX and 110 cross-connect systems, PS5E patch panels (including high density and modular versions) and related patch cords, outlets, modules, faceplates and adapters.

AX101067 GigaFlex PS6+ Module



Description	Belden Part Number
-------------	--------------------

Belden IBDN System 1200, Modules

GigaFlex PS5e Module	
T568A/B, White	AX101309
T568A/B, Black	AX101310

AX101571 Flex Patch Panel, Black



Description	Belden Part Number
-------------	--------------------

Belden IBDN System 1200, Patch Panels

GigaFlex PS5e Patch Panel	
GigaFlex PS5e HD-110 Patch Panel, 1U, 24-port, Black, T568B, loaded	AX100452
GigaFlex PS5e HD-110 Patch Panel, 2U, 48-port, Black, T568B, loaded	AX100454
Flex Patch Panel, 1U, 24-port, Black, unloaded	AX101571
Flex Patch Panel, 2U, 48-port, Black, unloaded	AX101458

AX102344 GigaFlex PS5E Modular Cord

Flexible Keyconnect panels also available, please refer to page 84

Description	Belden Part Number					
	Blue	White	Grey	Green	Red	Yellow



Belden IBDN System 1200, Modular Cords

GigaFlex PS5e Modular Cord, LSZH 4-pair, 24 AWG stranded, T568B - T568B						
0.5 m (1.6 ft.)	AX102344	AX102338	AX102386	AX102526	AX102532	AX102538
1.0 m (3.3 ft.)	AX102345	AX102339	AX102387	AX102527	AX102533	AX102539
2.0 m (6.5 ft.)	AX102346	AX102340	AX102388	AX102528	AX102534	AX102540
3.0 m (10.0 ft.)	AX102347	AX102341	AX102389	AX102529	AX102535	AX102541
5.0 m (16.4 ft.)	AX102348	AX102342	AX102390	AX102530	AX102536	AX102542
10.0 m (33 ft.)	AX102349	AX102343	AX102391	AX102531	AX102537	AX102543

1224.07U305 GigaFlex 1224 Cable

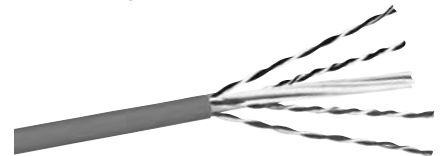

Description	Belden Part Number			
	Grey	Green	Red	Yellow

Belden IBDN System 1200, Cables

Category 5e • 24 AWG • UTP, 4-pair				
GigaFlex 1212, CMR, 305 m Box	1212.06U305	1212.05U305	-	-
GigaFlex 1213, CMP, 305 m Box	-	1213.009U1000	-	-
GigaFlex 1224, LSZH, 305 m Box	-	-	1224.07U305	-
DataTwist® 350, LSZH, 305 m Box	-	-	-	1700ENH.00430

This systems overview page is intended to give you a basic list of the main components used in the system. For a more complete listing of product options and for more detailed product information go to belden-emea.com.

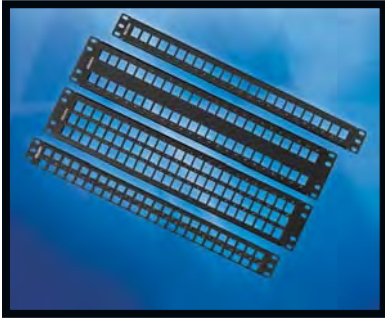

KeyConnect Patch Panel Series

The KeyConnect Patch Panel Series is a comprehensive line of robust all-metal, preloaded and modular patch panels. The series provides a flexible, versatile and high density termination solution for Data Center and Telecommunications Room installations.

The preloaded KeyConnect Patch Panels are available in 24-port/1U and 48-port/2U configurations with 10GX® and CAT6+ KeyConnect Modular Jacks.

The modular KeyConnect Patch Panels are available in 24-port/1U, 48-port/2U, 72-port/2U and 48-port/1U configurations. These panels can be configured using any KeyConnect UTP or Multi-media Modules.

Key Applications

- Horizontal distribution or equipment terminations in Data Centers or Telecommunications Rooms
- Interconnect terminations in Consolidation Points Installation Tips
- Plan the rack/cabinet layout prior to patch panel installation
- Include Cable Management products (see www.belden.com for more information) in installation for optimum cable and patch cord routing
- Use the LabelFlex software (see www.belden.com for more information) to print quality identification labels
- Use the Connecting Tool (AX100749) to terminate KeyConnect Modular Jacks directly in the patch panel or in the Termination Station (AX101852)
- Use the Release Tool (AX101185) to remove KeyConnect Modular Jacks from a patch panel
- Use the Patch Cord tool (AX102775) to insert or remove patch cords in high-density patch panels

Key Benefits

- Available in a wide variety of preloaded and modular configurations for greater design flexibility and optimization of rack and cabinet installations
- Robust all-metal construction to allow for punch down termination directly on the back of the panel
- Large front labeling space facilitating port identification
- LabelFlex laser printable white label sheet supplied with each panel
- Front and back port numbering to facilitate port location
- Rear cable management brackets to facilitate cable routing
- Compatible with standard 19" equipment racks, cabinets or wall mount brackets
- Compatible with KeyConnect Modular Jacks



The AngleFlex Patch Panel Series

The AngleFlex Patch Panel Series is a new line of patch panels that provides better manageability and improved installation flexibility for Data Center and Telecommunications Room installations. AngleFlex Patch Panels are available in 24-port/1U and 48-port/2U configurations. These panels can be configured using any KeyConnect™ UTP or Multimedia Modules.

Each reversible angled insert of the AngleFlex Patch Panel can be situated for intuitive patch cord routing to the left, right or a combination of both. This facilitates bundling and eliminates the need for horizontal cable managers that require additional rack space. Because AngleFlex allows all patch cords to be routed to one side – either left or right – a vertical cable manager can also be eliminated for a 27% space savings per rack. Or, the user could incorporate additional racks per row in a Data Center application. With most of today's installed switches requiring all connections to be made from one side, the ability to route all patch cords in one direction provides more efficient patch panel-to-switch interconnection, reducing patch cord lengths and eliminating complicated routing.

Because each of the angled inserts is removable, jack termination can be accomplished faster, at the front of the rack. Front access is also ideal for wall-mount applications or when space is limited at the rear of the rack. With jacks oriented sideways, patch cord routing with AngleFlex is not only easier, but also ensures optimum performance because the pins of the jack and plug are aligned properly against each other for better contact.

Key Applications

- Horizontal distribution or equipment terminations in Data Centers or Telecommunications Rooms
- Interconnect terminations in Consolidation Points

Key Benefits

- Patent-pending angles provide intuitive left, right or bi-directional patch cord routing and more efficient switch connection
- Removable angled inserts provide front access for easier termination and maintenance
- Provides a shallower, low-profile design for more room inside cabinets
- Angled inserts eliminate the need for horizontal cable management
- Jack orientation provides more reliable connection performance
- Angled design provides more labeling space for overall easier identification
- LabelFlex laser printable white label sheet supplied with each panel
- Rear cable management brackets facilitate cable routing
- Compatible with standard 19 in. equipment racks, cabinets or wall-mount brackets
- Compatible with KeyConnect Modular Jacks

Installation Tips

- Plan the rack/cabinet layout prior to patch panel installation
- Include Cable Management products in installation for optimum cable and patch cord routing
- Use the LabelFlex software to print quality identification labels
- Use the Connecting Tool (AX100749) to terminate KeyConnect Modular Jacks in the Termination Station (AX101852)
- Use the Release Tool (AX101185) to remove KeyConnect Modular Jacks from a patch panel



AX101985 GigaBIX Rack Mount Termination Kit, 48-port

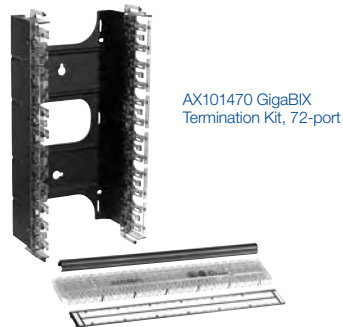

AX101470 GigaBIX Termination Kit, 72-port

AX101447 GigaBIX Connector, 6-port

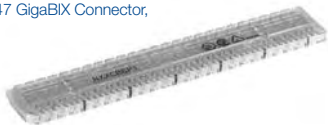

AX101986 GigaBIX Rack Mount Panel

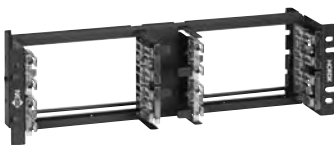

AX101472 GigaBIX Mount



GigaBIX Multi System

GigaBIX Termination Kits

The GigaBIX termination kits contains all components required to terminate cables in a GigaBIX cross-connect or interconnect system. The termination kits allow for the most cost-effective Category 6 cross-connect or interconnect installations using GigaBIX cross-connect wire or GigaBIX PS6+ patch cords. The GigaBIX mount is designed to accommodate high-performance cables. The GigaBIX connectors have color-coded edges, separation marks and a keying feature that prevents connector insertion in the wrong orientation. Each kit also contains wire guards, designation strips, designation labels, velcro ties and a detailed installation guide.

GigaBIX Connector

The GigaBIX connector is the core component of the GigaBIX multi system. Its symmetrical construction allows termination of high-performance cables on one side and GigaBIX cross-connect wires or GigaBIX patch cords on the other. Each GigaBIX connector is equipped with 50 double-ended Insulation Displacement Connection (IDC) clips for terminating plastic insulated solid copper conductors without stripping. The connector is built with two staggered rows of IDC clips enclosed in a three-layer construction of fire-retardant plastic wafers. The GigaBIX connectors have color-coded edges, separation marks and a keying feature that prevents connector insertion in the wrong orientation. The GigaBIX connector offers exceptional performance that goes beyond Category 6 which makes it the ideal choice for gigabit cabling networks.

GigaBIX Mount

The GigaBIX mount for wall installations holds 12 GigaBIX connectors and is designed to accommodate up to 144 high-performance cables when used in a top-to-bottom cross-connect layout. The GigaBIX rack mount panel allows for customizing rack mount installations for data, voice or multimedia installations. This panel can accommodate up to 8 GigaBIX connectors, for a total of 48 terminations of 4-pair UTP cables, or up to 4 GigaBIX/MediaFlex adapters for a total of 48 multimedia ports.

GigaBIX Wire Guard

The GigaBIX wire guards are plastic strips that snap behind the GigaBIX connectors after termination to provide strain relief to the twisted pairs. They come as part of the GigaBIX termination kits and can also be ordered separately as replacement components.

GigaBIX Designation Strip

The GigaBIX designation strips are plastic strips that snap between the GigaBIX connectors to apply the designation labels. They come as part of the GigaBIX termination kits and can also be ordered separately as replacement components.

GigaBIX/MediaFlex Adapter

The GigaBIX/MediaFlex adapter allows for mixed media installation within the expanded GigaBIX multi-family of connectivity. The GigaBIX/MediaFlex adapter can accommodate a variety of MediaFlex inserts including UTP and multimedia inserts to customize multimedia installation in telecommunications rooms, equipment rooms, or consolidation points.



Description	Belden Part Number
GigaBIX Multi System	
Termination Kits	
GigaBIX Termination Kit, 72-port	AX101470
GigaBIX Termination Kit, 300-pair	AX101471
GigaBIX Rack Mount Termination Kit, 48-port	AX101985
Basic Components	
GigaBIX Connector, 6-port	AX101447
GigaBIX Connector, 25-pair	AX101448
GigaBIX Mount, 12-connector	AX101472
GigaBIX Rack Mount Panel, 48-port	AX101986
GigaBIX Wire Guard	AX101486
GigaBIX Designation Strip	AX101483
GigaBIX/MediaFlex Adapter	AX101987

These products are in the process of being assessed for RoHS compliance. Please check our website for the most current RoHS status.

AX101486 GigaBIX Wire Guard



AX101483 GigaBIX Designation Strip, shown here with label

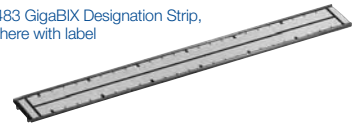

AX101987 GigaBIX/MediaFlex Adapter



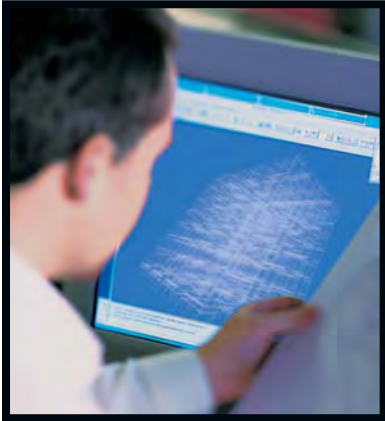

Optical Fiber Connectivity

For even faster solutions Belden is offering the *FiberExpress*[®] and now the *FiberExpress*[®] Ultra Solutions. These are complete end-to-end cabling systems which support both centralised and FTTD (Fiber To The Desk) topologies. These solutions also support backbone and campus cabling configurations and meet or exceed all applicable TIA/EIA, ISO/IEC and IEEE standards.

Key Benefits

- High bandwidth and transmission speed
- The potential for network growth
- Extended reach – distance
- Fault tolerance
- Greater data security
- Support for Gigabit and multi-Gigabit protocols and networked applications
- Reduced design complexities
- Quick installation
- Increased flexibility

Key Products

FiberExpress[®] Cables

A variety of multimode and single-mode optical fiber cables are available for in-building and inter-building applications including:

- [Distribution Cables](#)
Tight Buffer, Indoor and Outdoor, Riser, Plenum and LSZH Rated
- [Breakout Cables](#)
Tight Buffer, Indoor Riser, Plenum and LSZH Rated
- [Loose Tube \(Campus\) Cables](#)
Indoor/Outdoor, LSZH, Plenum and Riser Rated

FiberExpress[®] Cross-Connect Hardware

A number of products are available for the Cross-Connect, including:

- [FiberExpress[®] Ultra Patch Panel System
This system offers users ultra high density coupled with ultra-easy installation and maintenance, and ultra manageability. It integrates seamlessly with all *FiberExpress*[®] cables, connectors and management components.](#)

FiberExpress[®] Manager with *FiberExpress*[®] Manager Connector Modules

The *FiberExpress*[®] Manager uses a scalable, modular approach to streamline termination, connection and maintenance of in-building installations. The *FiberExpress*[®] Manager's Connector Module is its basic building block, supporting all major connector types.



FiberExpress® Rack-mount Patch Panels with Universal Adapter Strips

These components can be used with tight-buffered or loose-tube optical fiber cables and they can be tailored to specific needs in terms of density and management.

See the following Data Sheets for more information:

- 1U Rack-mount
- 2U Rack-mount
- 3U Rack-mount
- 4U Rack-mount

FiberExpress® Wall-mount Patch Panels with Universal Adapter Strips

Wall-mount Patch Panels are ruggedly constructed plus they constitute an economical solution for the protection of fiber terminations and splices in hostile environments.

FiberExpress® Bar (Multimode and Single-mode)

The FiberExpress® Bar is a compact fiber patch panel that consists of a custom length fiber cable with a factory pre-terminated mini-patch panel at one end and a factory installed multi-fiber MPO connector at the other end.

FiberExpress® Patch Cord and Cable Assemblies

Our FiberExpress® Patch Cord assemblies are of the highest quality available. They are assembled and 100 percent optically tested in our factory prior to shipment.

FiberExpress® Multi-fiber Cable Assemblies

These Cable Assemblies consist of factory-terminated fiber cables of various constructions using simplex, duplex or multi-fiber connections.

FiberExpress® Connectors

The FiberExpress® System offers both field-installable and epoxy field-mountable connectors:

- **Optimax Optical Fiber Connectors**
These reliable, field-installable optical fiber connectors are easy to install, and require no epoxy, curing or polishing. All critical steps are performed in the factory, thus ensuring a superior quality connection every time. The Optimax Tool Kit contains the tools and instructions needed to deploy the Optimax Connectors.
- **Epoxy Field-mountable Connectors**
Our epoxy connectors are available as Multimode and Single-mode ST Compatible and SC field installable connectors, both with a ceramic ferrule. They require heat-cured epoxy and polishing.

Work Area Outlets

Outlets for Fiber-To-The-Desk installations include the following:

- **MDVO Multimedia Outlets with MDVO Multimedia Modules**
MDVO outlets bring unique versatility for multimedia work area installations, offer easy cable management and protection for patch cords. The outlet box can be mounted directly on the wall or attached to standard electrical boxes.



Networking-Copper Cables



Cables That Communicate

Unshielded and Shielded Twisted Pair cables are typically used for data transmission. To help achieve optimum network performance, Belden® has built reliability into each cable it produces. The result is a comprehensive, unfailing line of cables that fulfill the requirements of a specific application and/or the applicable TIA/EIA Category requirement. Belden has become the international byword for premium quality, performance and reliability, an accolade for excellence earned through decades of dedication to meeting the highest industry standards. Our objective is to provide our customers with superior solutions for their cabling requirements. Accordingly, all our solutions are based on, performance, innovation and reliability.

The Belden Networking cabling portfolio caters for all current protocols, and are backwardly compatible. Our cables exceed the industry standards, including TIA/EIA, ISO/IEC and EN (BSI) standards. There is a wide range of constructions available, including:

- Category 5e, 6, 6a, 7
- Unshielded (U/UTP)
- Shielded
 - F/UTP: Foil Twisted Pair Construction
 - SF/UTP: Braid and Foil Twisted Pair
 - S/FTP: Braid over individually Foil Twisted Pairs

The Networking Cables are available in the following sheath types:

- PVC: Poly Vinyl Chloride
- LSNH: Low Smoke Non Halogen
- PE: Polyethylene
- CMR: Riser Rated PVC
- CMP: Plenum Rated

Key Applications

- Ethernet – 10/100/1000/10G-Base Tx
- IP: Internet Protocol
- VOIP: Voice Over IP
- Video
- PoE: Power over Ethernet
- BAS: Building Automation Services
- Automation processes



Key Products

Bonded-Pair Cables

Belden's breakthrough Bonded-Pair cables are the result of a patented design that bonds the individual insulated conductors together along their longitudinal axes. This unique physical characteristic results in uniform conductor-to-conductor spacing – a key aspect in consistent electrical performance. Even when a Bonded-Pair cable is subjected to everyday installation stresses such as bending, coiling and pulling, its conductor-to-conductor spacing remains stable.

A Category 5e cable that yields 5e performance on the reel, but provides only Category 5 performance after being installed, is of little value. Since Belden Bonded-Pair cables are more resistant to the adverse effects of the installation/termination process, they are able to achieve Installable Performance – or they achieve the same high level of performance after installation.

Paired cables allow balanced signal transmission, which results in lower crosstalk through common mode rejection. Due to the improved noise immunity of twisted pairs, they generally permit higher data speeds than multi-conductor cables.

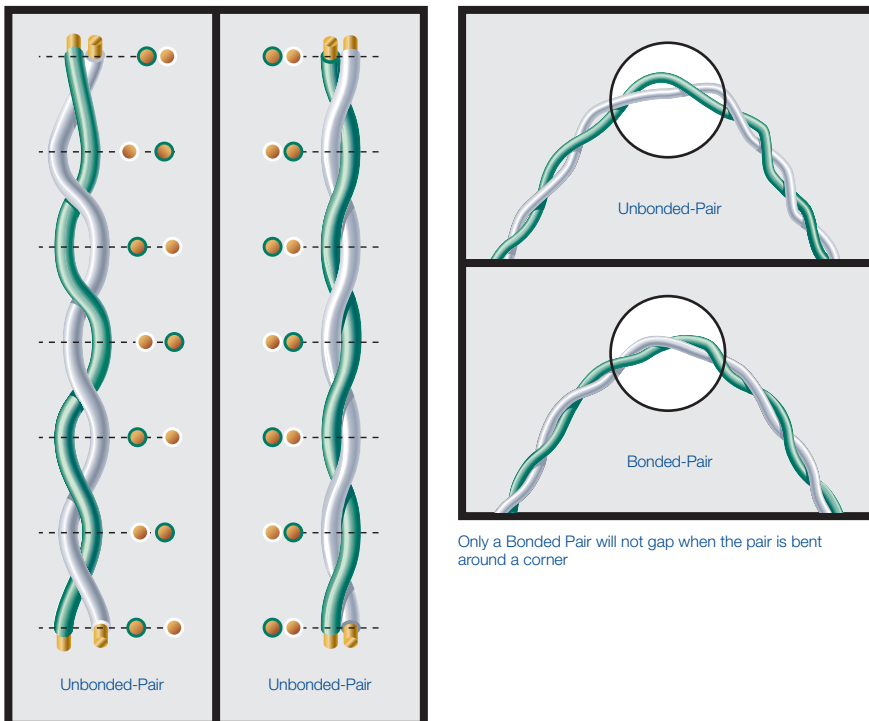

The Ideal twisted pair, with perfect centricity and concentricity

Unshielded Cables

Part No.	Description	Tested to Frequency (MHz)	Remarks	Industry Standards		
				EN 50173-1	TIA/EIA 568-B2	ISO/IEC 11801 2nd ed.

Unshielded Cables

UTP Category 5e						
1700A	DataTwist® 350	350	Bonded-Pair	•	•	•
1702A	Twin 1700A	350	Bonded-Pair	•	•	•
1700E	DataTwist® 350	350	Bonded-Pair	•	•	•
1700ENH	DataTwist® 350	350	Bonded-Pair, NH Jacket	•	•	•
1702E	Twin 1700E	350	Bonded-Pair	•	•	•
1702ENH	Twin 1700ENH	350	Bonded-Pair, NH Jacket	•	•	•
1583A	DataTwist® 5e	200	–			
1583E	UTP Cat 5e PVC	100	–	•	•	•
1583ENH	UTP Cat 5e LSNH	100	NH Jacket	•	•	•
1667E	Twin 1583E	100	–	•	•	•
1667ENH	Twin 1583ENH	100	NH Jacket	•	•	•
1592A	DataTwist® 5e Patch	350	–		•	•
1752A	DataTwist® 350 Patch	350	Bonded-Pair		•	•
UTP Category 6						
7965E	UTP CAT 6 PVC	250	–	•	•	•
7965ENH	UTP CAT 6 LSNH	250	NH Jacket	•	•	•
7812E	UTP CAT 6 PVC	250	Bonded-Pair	•	•	•
7812ENH	UTP CAT 6 LSNH	250	Bonded-Pair, NH Jacket	•	•	•
1872A	MediaTwist®	350	Bonded-Pair		•	•
1875GB	MediaTwist® Patch	350	Bonded-Pair		•	•
7851A	DataTwist® 600e	600	Bonded-Pair		•	

Plenum versions and various multipair cables available upon request. Please check for available outdoor cables.



Shielded Cables

Part No.	Description	Tested to Frequency (MHz)	Remarks	Industry Standards		
				EN 50173-1	TIA/EIA 568-B2	ISO/IEC 11801 2nd ed.
Shielded Cables						
(S)FTP Category 5e						
1633E	F/UTP CAT 5e PVC	100	–	•		•
1633ENH	F/UTP CAT 5e LSNH	100	NH Jacket	•		•
1668E	Twin 1633E	100	–	•		•
1668ENH	Twin 1633ENH	100	NH Jacket	•		•
1730A	F/UTP CAT 5e PVC	100	Bonded-Pair			•
1730ANH	F/UTP CAT 5e LSNH	100	Bonded-Pair, NH Jacket			•
1633ES	Braided 1633E	100	–	•		•
1633ENS	Braided 1633ENH	100	NH Jacket	•		•
1668ES	Twin 1633ES	100	–	•		•
1668ENS	Twin 1633ENS	100	NH Jacket	•		•
1868E	Patch	100	–	•		•
1868ENH	Patch	100	NH Jacket	•		•
(S)FTP Category 6						
7860E	SF/UTP CAT 6 PVC	250	Bonded-Pair	•		•
7860NBH	–	250	–	•		•
7860ENH	SF/UTP CAT 6 LSNH	250	Bonded-Pair, NH Jacket	•		•
7860ES	Braided 7860E	250	Bonded-Pair	•		•
7860ENS	Braided 7860ENH	250	Bonded-Pair, NH Jacket	•		•
(S)FTP Category 7						
1885ENH	–	1000	NH Jacket	•		•
1887ENH	Twin 1885ENH	1000	NH Jacket	•		•

Plenum versions and various multipair cables available upon request. Please check for available outdoor cables.

GLOBAL LOCATIONS

We always have the right data communications solution for your specific application.

Talk to us about what you need now and where you are going tomorrow.



CONTACT FOR BELDEN® BRAND

Edisonstraat 9
5928 PG Venlo
The Netherlands

Phone: +31-77-3878-555
Fax: +31-77-3878-488
www.beldensolutions.com
venlo.salesinfo@belden.com

CONTACT FOR HIRSCHMANN™ BRAND

Stuttgarter Straße 45-51
72654 Neckartenzlingen
Germany

Phone: +49-7127-14-0
Fax: +49-7127-14-1970
www.beldensolutions.com
inet-sales@belden.com

CONTACT FOR LUMBERG AUTOMATION™ BRAND

Im Gewerbepark 2
58579 Schalksmühle
Germany

Phone: +49-2355-5044-000
Fax: +49-2355-5044-333
www.beldensolutions.com
lac-info@belden.com